

YASKAWA Nordic AB
Positioners, tracks and gantry



Definitions

General information

Name of positioner axes:

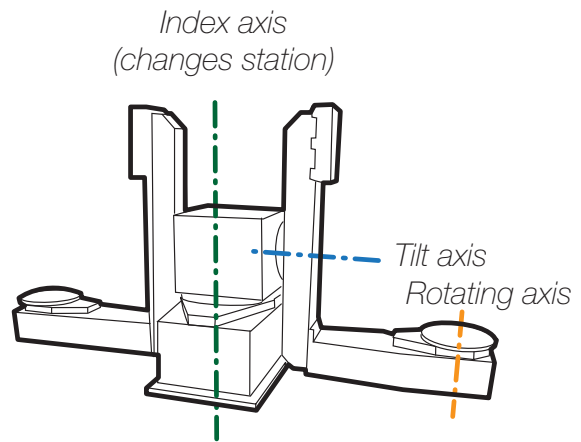
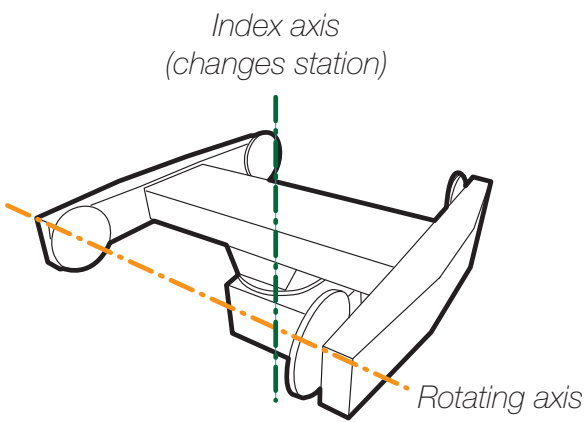

Positioner category: one axis (workpieces that require rotation around one axis)

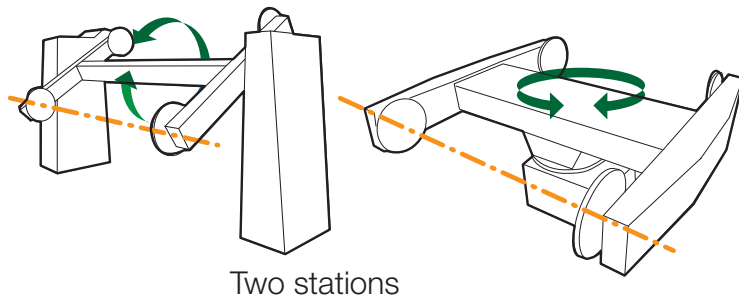
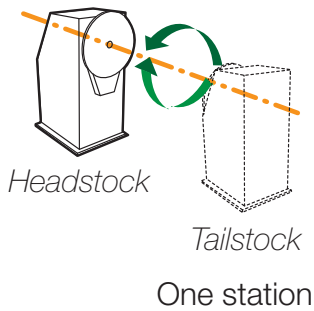

Positioner category: two axes (workpieces that require rotation around two axes)

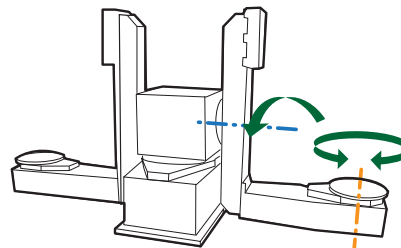
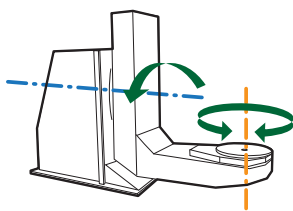

Examples

Standard products	4
Customized standard	6

One axis positioner

SB [1030-EN]	8
HSC [1014-EN]	10
HSD [1015-EN].....	12
HSB-1000, -2000, -5000 [1012-EN]	14
HSB-7000, -10000, -20000 [1013-EN]	16
SPD [1032-EN]	18
SPB [1031-EN]	20
RM2 (STN) [1023-EN]	22
RM2 (TN) [1024-EN]	24
RM2 (S3D) [1007-EN]	26
RM2-1000 (S3D) [1025-EN]	28
VMH (CDD) [1046-EN]	30
VMH-250, -500 [1044-EN]	32
VMH-1000 [1045-EN]	34

Two axes positioner

MT1-250 [1016-EN]	36
MT1-500 [1061-EN]	38
MT1-1000, 1500 [1017-EN]	40
MT1-3000, 5000 [1018-EN]	42
VMF (S5DL) [1042-EN]	44
VMF (S5D) [1043-EN]	46

Rotating module

VMS [1048-EN]	48
---------------------	----

Light series (M)

HSC (M) [1051-EN]	50
HSD (M) [1052-EN]	52
SPE [1062-EN]	54
SPH [1064-EN]	56
SPF [1063-EN]	58
VMH (M) [1053-EN]	60
VMI [1054-EN]	62

Rotating robot base & tracks

VST [1049-EN]	64
TSL-600 [1050-EN]	66
TSL-1000 [1036-EN]	68
TSL-2000, -4000 [1047-EN]	70

Gantry

TSG [1034-EN]	72
TSG options [1065-EN]	74
HD [1011-EN]	76

Positioner options

Controlled air and signal transfer	78
--	----

Configuration

External axis configuration	79
-----------------------------------	----

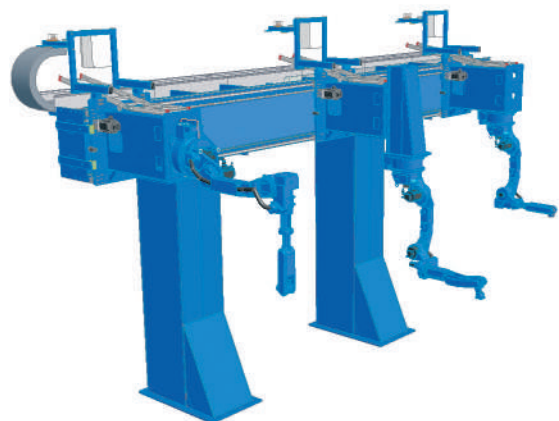

Examples

Standard products

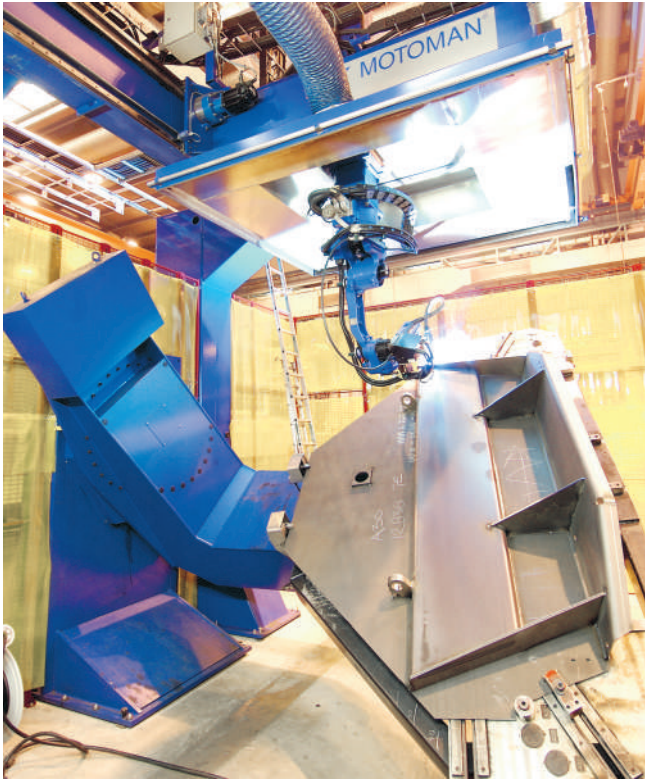

Standard gantry and MT1 turn-tilt positioner for welding large objects.



Access to the top of the gantry through service ladders with a platform.

A single MOTOMAN-ES165 is serving several CNC machines as it travels along the servo powered track.





Press brake application with a robot and accompanying equipment that travels on the servo powered track.



Increased working range for the robot mounted on a VST rotating base.

One pillar gantry and positioner in an FMS system designed for a highly flexible, on-demand production.

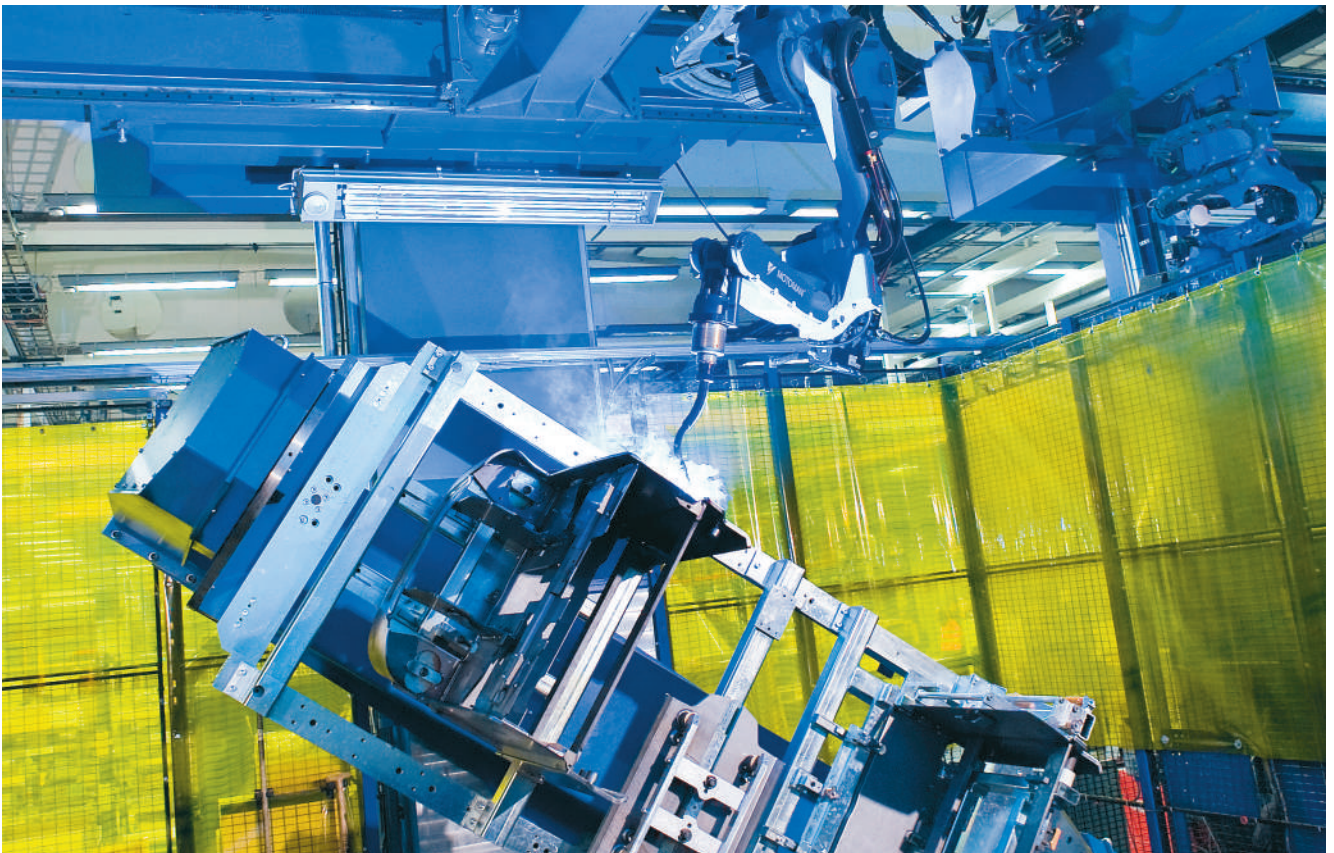

Customized standard

Modular design possibilities

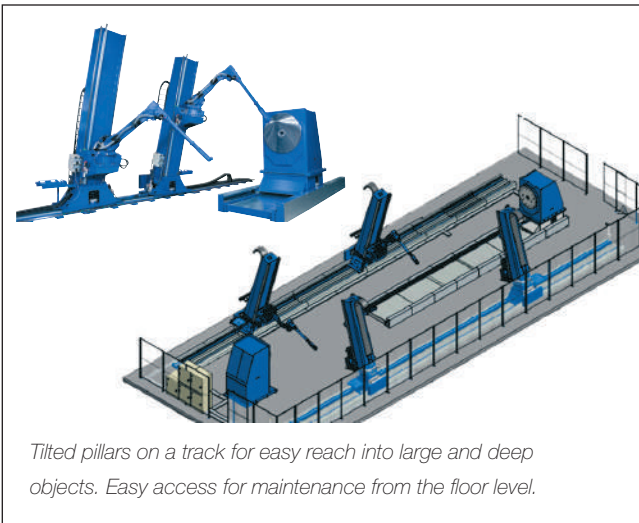
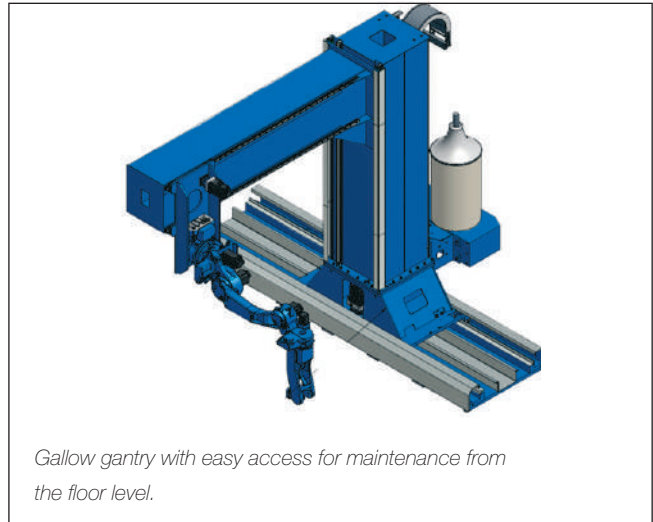
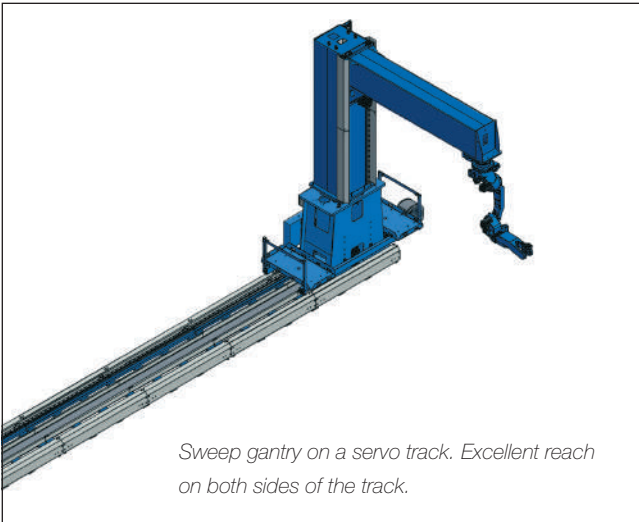
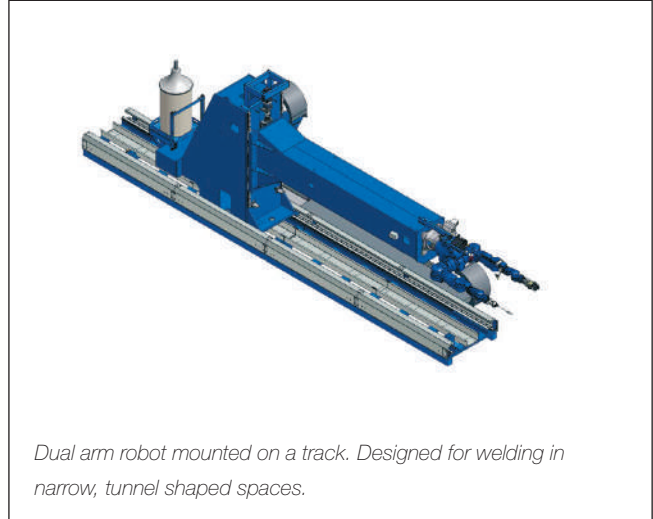
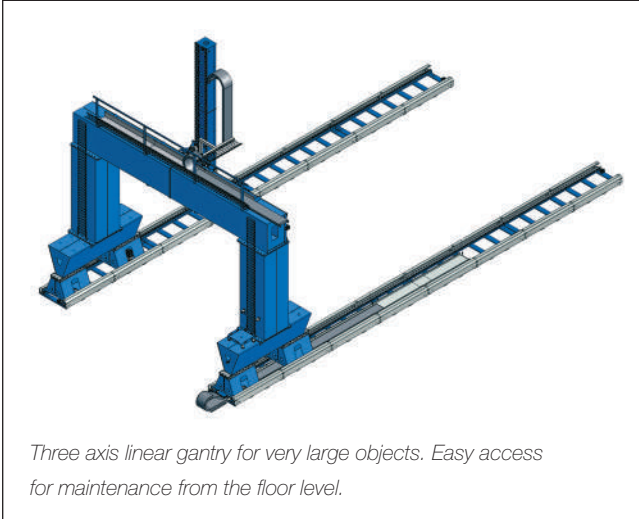

Customized standard

Modular design possibilities

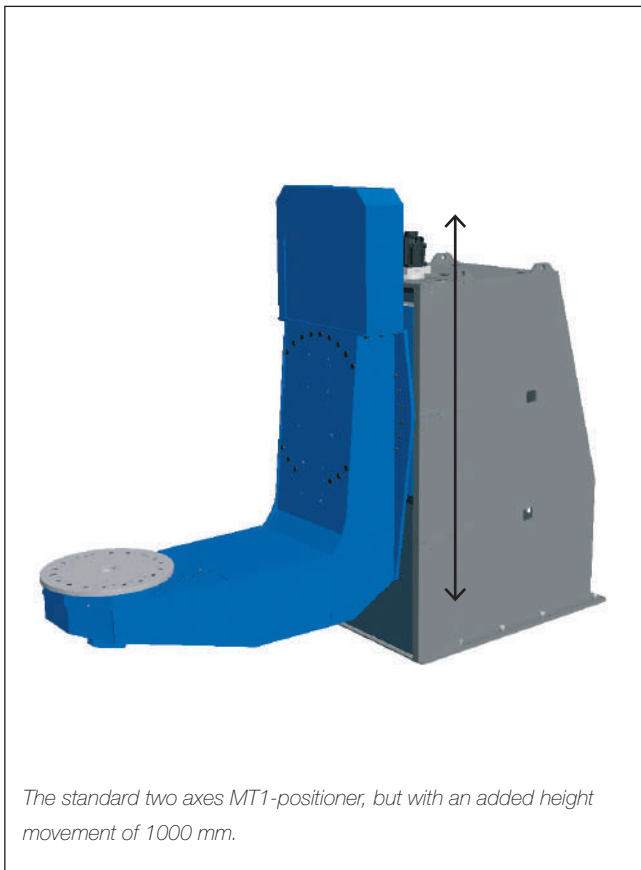
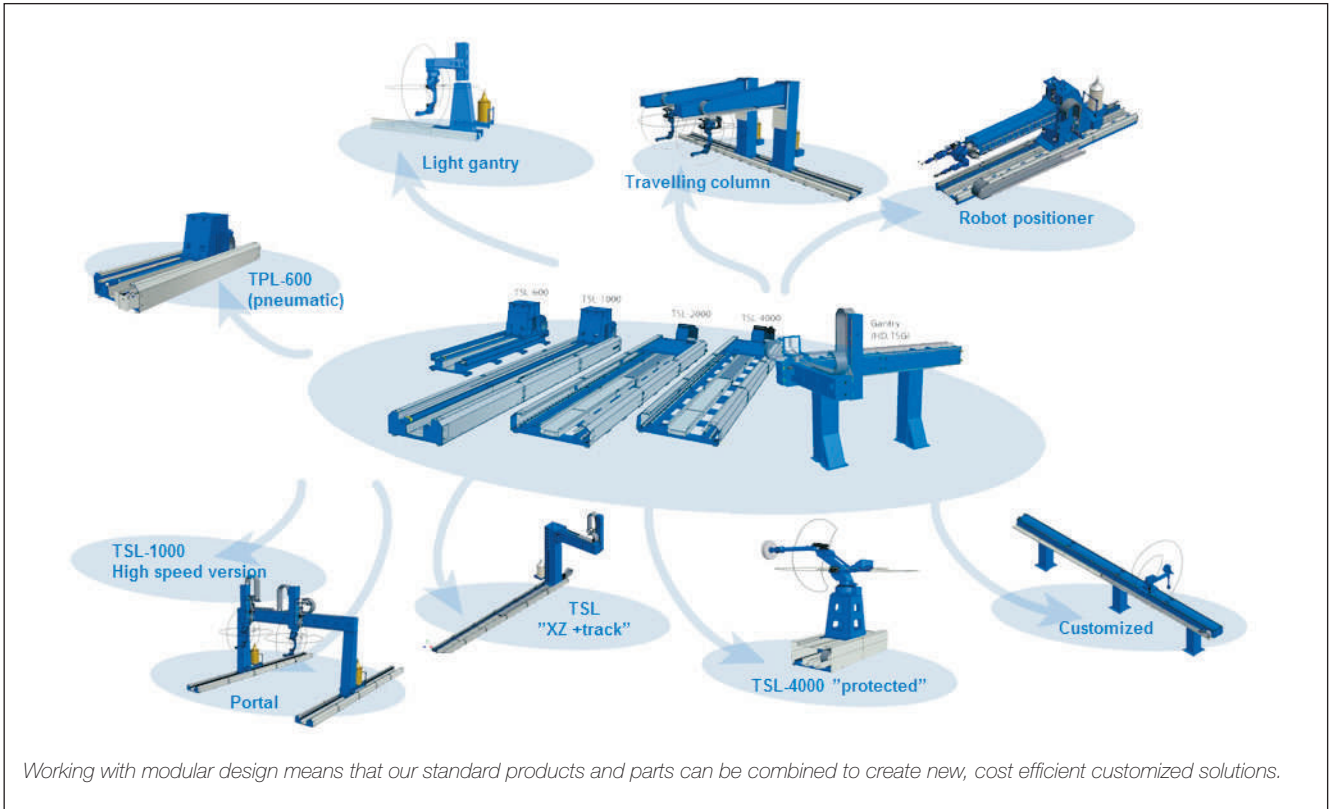

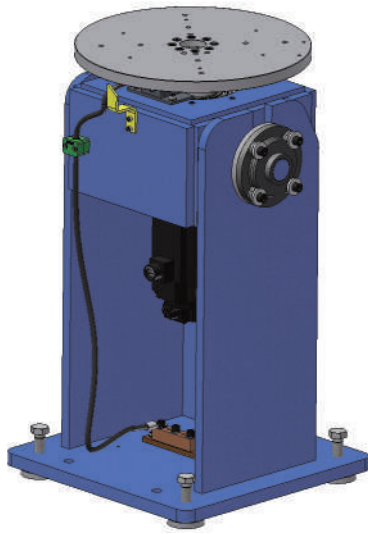

- Compact, space saving design
- Direct drive
- Endless rotation

This is one station positioner for workpieces requiring rotation about one axis. It is a stand alone positioner to be used without tailstock and suitable for integration in e.g. compact welding stations.

The SB positioner can be used with its rotating fixture disc mounted in five positions from vertical to horizontal. The position of the fixture disc is change manually.

The SB positioner is suitable for workpieces with a diameter up to 1300 mm.

Technical data		SB-250 SD
Maximum payload	kg	250
Welding capacity, 100 % duty cycle	A	350
Welding capacity, 60 % duty cycle	A	460
Maximum fixture width, radius = H	mm	425, 655
<i>Rotating axis</i>		
Torque, dynamic	Nm	1046
Torque, static	Nm	837
Rated offset from the center of gravity (COG)	mm	341
Rated speed	rpm	0-16.5

SB-250 SD

Possible tilt:
22.5°, 45° and 67.5°

Rotating axis
(vertical)

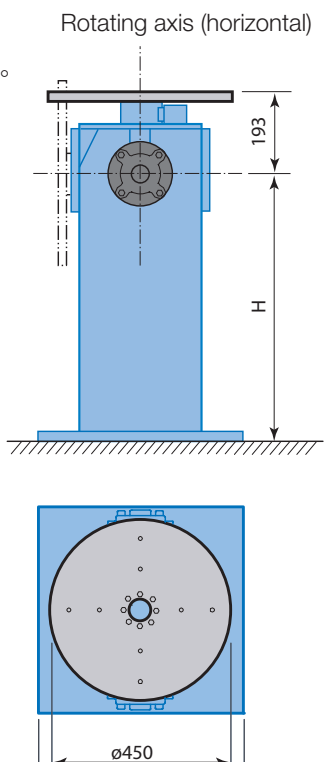

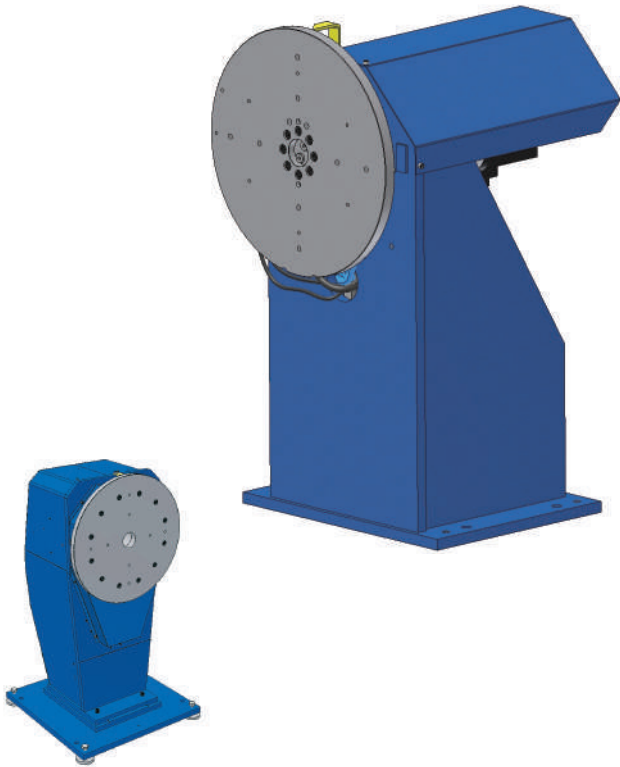

HSC-500 SD

- Stand-alone design
- Direct drive
- Endless rotation

This is one station positioner for workpieces requiring rotation about one axis. It is a stand alone positioner to be used without tailstock and suitable for integration in e.g. compact welding stations.

The HSC positioner is suitable for workpieces with a diameter up to 2450 mm. Maximum payload up to 500 kgs.

Available accessories

- Controlled air
- Slip ring device

Technical data		HSC-250 SD		HSC-500 SD					
Maximum payload	kg	250		500					
Welding capacity, 100 % duty cycle	A	350		350					
Welding capacity, 60 % duty cycle	A	460		460					
Maximum fixture's width, diameter	mm	900	1200	1250	1550	1750	2050	2250	2450
Height to fixture disc's center (H)	mm	470	700	650	800	900	1050	1150	1250
	<i>Rotating axis</i>								
Torque, dynamic	Nm	1108		2600					
Torque, static	Nm	886		2080					
Rated offset from the center of gravity (COG)	mm	360		424					
Rated speed	rpm	0-12.6		0-5.3					
Maximum speed	rpm	25.2		15					

HSC-250 SD

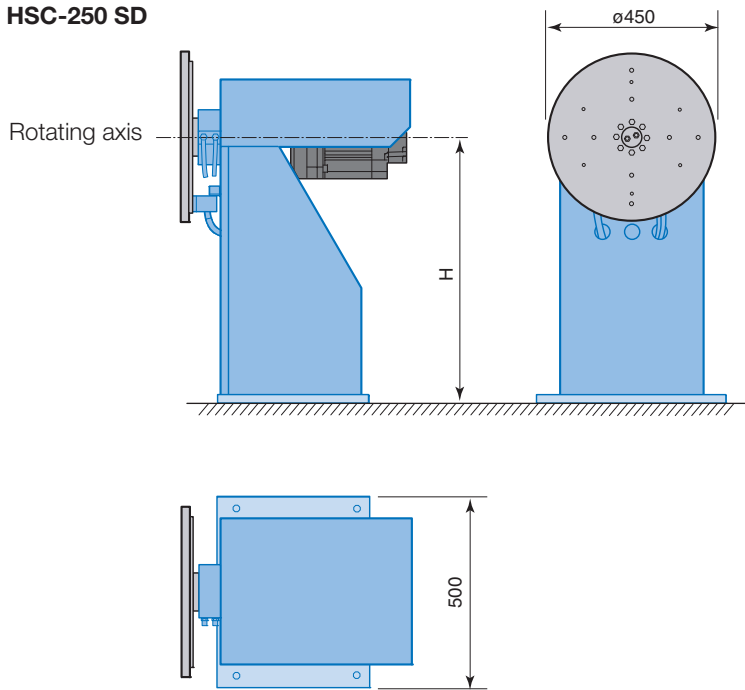

HSC-500 SD

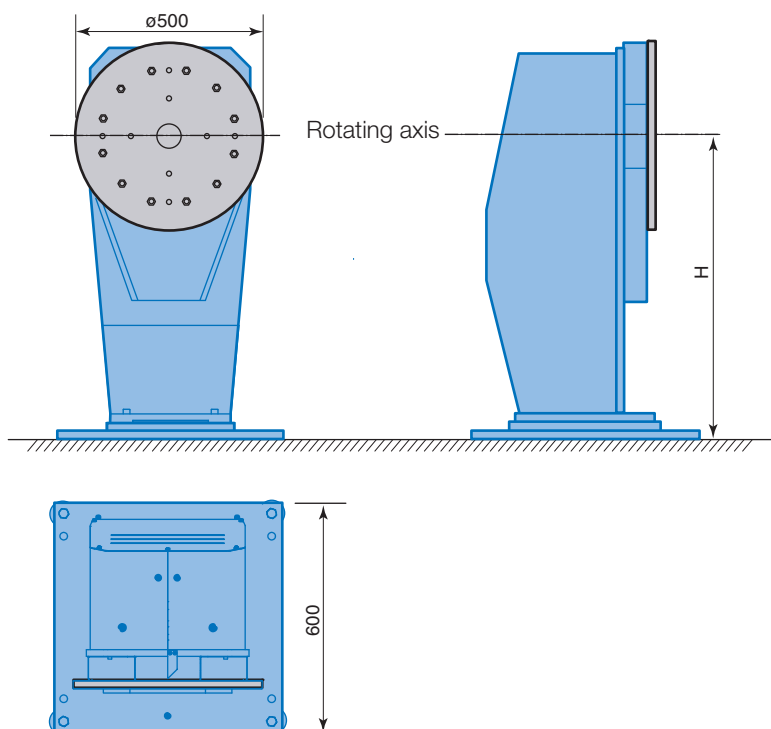

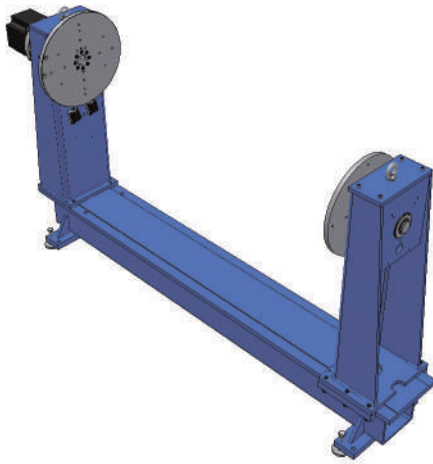

- Easy to install
- Direct drive
- Endless rotation
- Adjustable length

This is one station positioner for workpieces requiring rotation about one axis. It is equipped with a tailstock that can be moved manually along the centre beam to any position within the range (L) shown in the table.

Available accessories

- Slip ring device
- Controlled air
- Fixture brackets

Technical data		HSD-500 SD	HSD-750 SD	HSD-1000 SD
Maximum payload	kg	500	700	1000
Welding capacity, 100 % duty cycle	A	2 x 350	2 x 350	2 x 350
Welding capacity, 60 % duty cycle	A	2 x 460	2 x 460	2 x 460
Distance between fixture plates (L)	mm	1600, 2600, 3600 ¹⁾	1600, 2600, 3600 ¹⁾	1600, 2600, 3600 ²⁾
Maximum fixture's width, radius (R)	mm	750, 1000	750, 1000	750, 1000
Height (H)	mm	R +280	R +280	R +280
<i>Rotating axis</i>				
Torque, dynamic	Nm	952	1330	2600
Torque, static	Nm	762	1064	2080
Rated offset from the center of gravity (COG)	mm	155	144	212
Rated speed	rpm	0-10.6	0-10.7	0-5.3
Maximum speed	rpm	35.0	30.0	15.0

¹⁾ Also available: 2200, 3000, 3300, 4000, 4500 mm

²⁾ Also available: 2300, 3000, 4000, 4500 mm

HSD-500 SD, HSD-750 SD

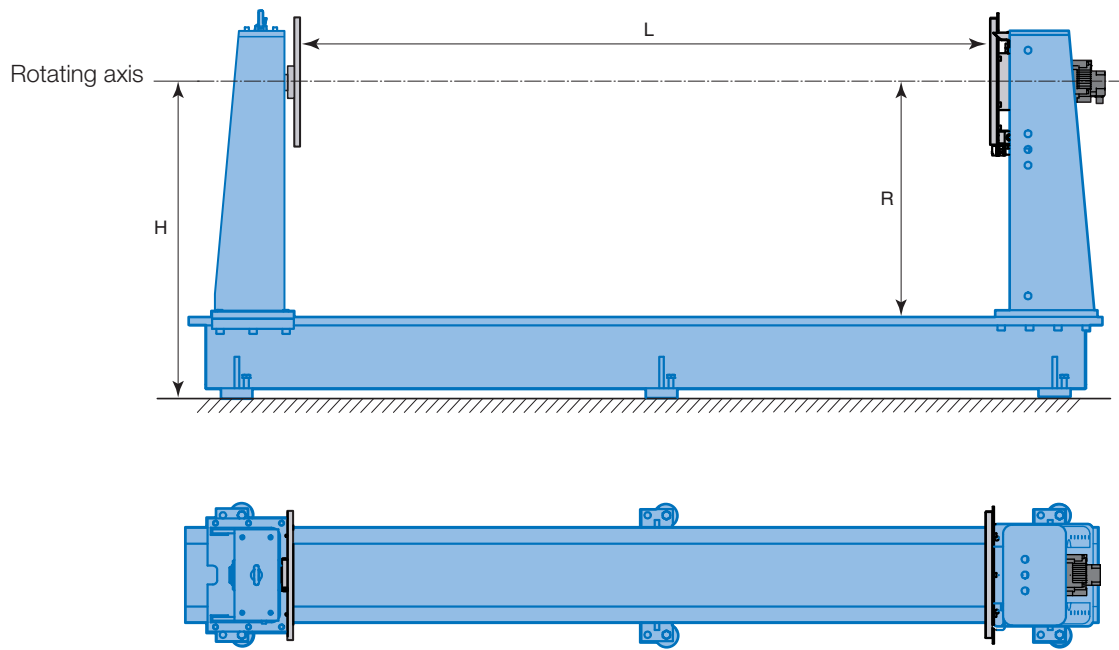

HSD-1000 SD

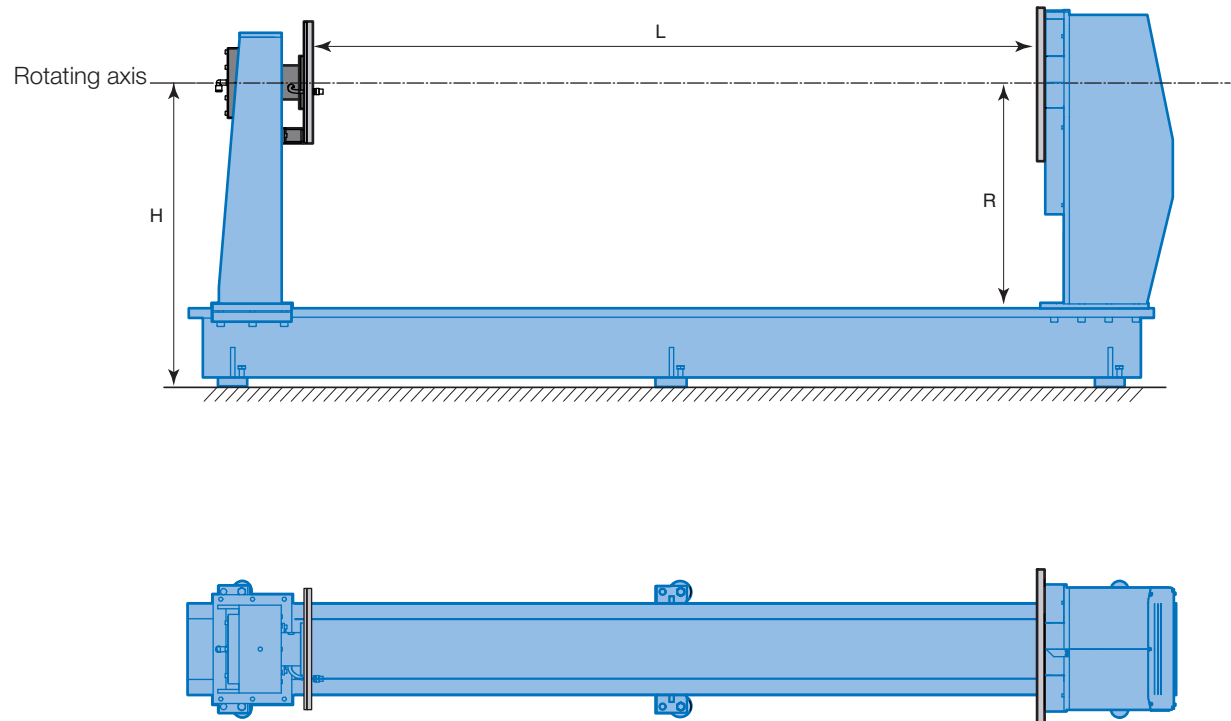

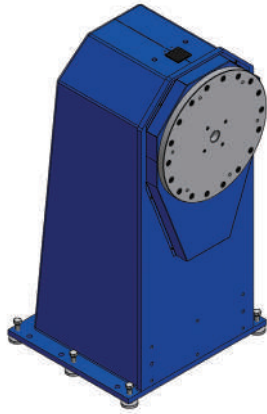

- Rigid design
- Supplementary tailstocks
- Heavy duty

This is a one station positioner for workpieces requiring rotation about one axis.

To support long workpieces it is advisable to use a supplementary tailstock. The free standing tailstocks can be mounted directly on the floor at an appropriate distance from the positioner.

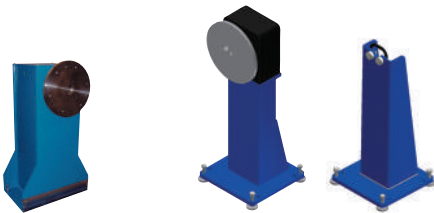

SPB

SPE, SPF, SPH

Available accessories

- Fixture brackets
- Tailstocks

Technical data		HSB-1000 SD2	HSB-2000 SD2	HSB-5000 SD
Maximum payload	kg	1000	2000	5000
Welding capacity, 100 % duty cycle	A	350	2x 350	2x 350
Welding capacity, 60 % duty cycle	A	460	2x 460	2x 460
Maximum fixture's width, radius = H	mm	970, 1200, 1500 ¹⁾	970, 1200, 1500	970, 1200, 1500
<i>Rotating axis</i>				
Torque, dynamic	Nm	2600	3818	6315
Torque, static	Nm	2080	3054	5052
Rated offset from COG	mm	212	155	103
Rated speed	rpm	0-5.3	0-3.6	0-3.4
Maximum speed	rpm	15	9.6	9.1
Tailstock, free standing		SPB, SPE, SPF, SPH	SPB-2000	SPB-2000, -7000

¹⁾Also available: 650 and 850 mm

HSB-1000 SD2

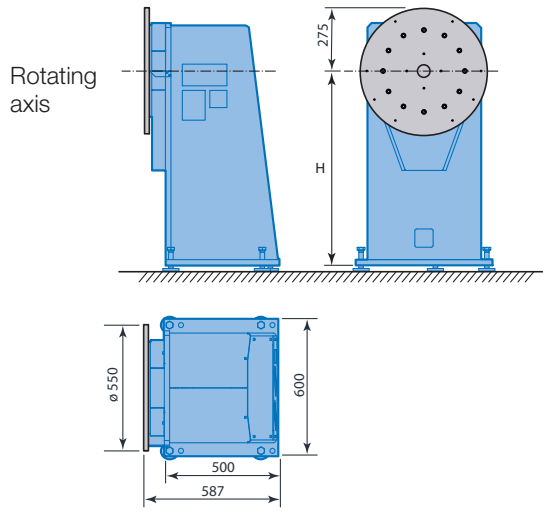

HSB-2000 SD2

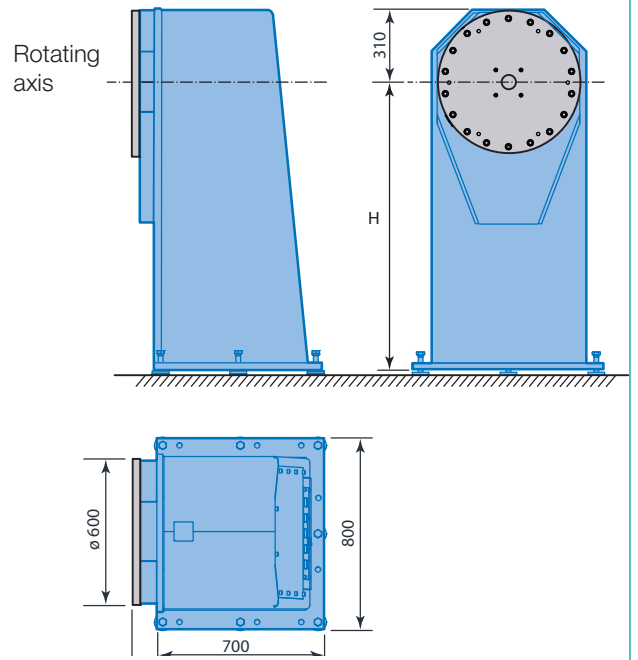

HSB-5000 SD

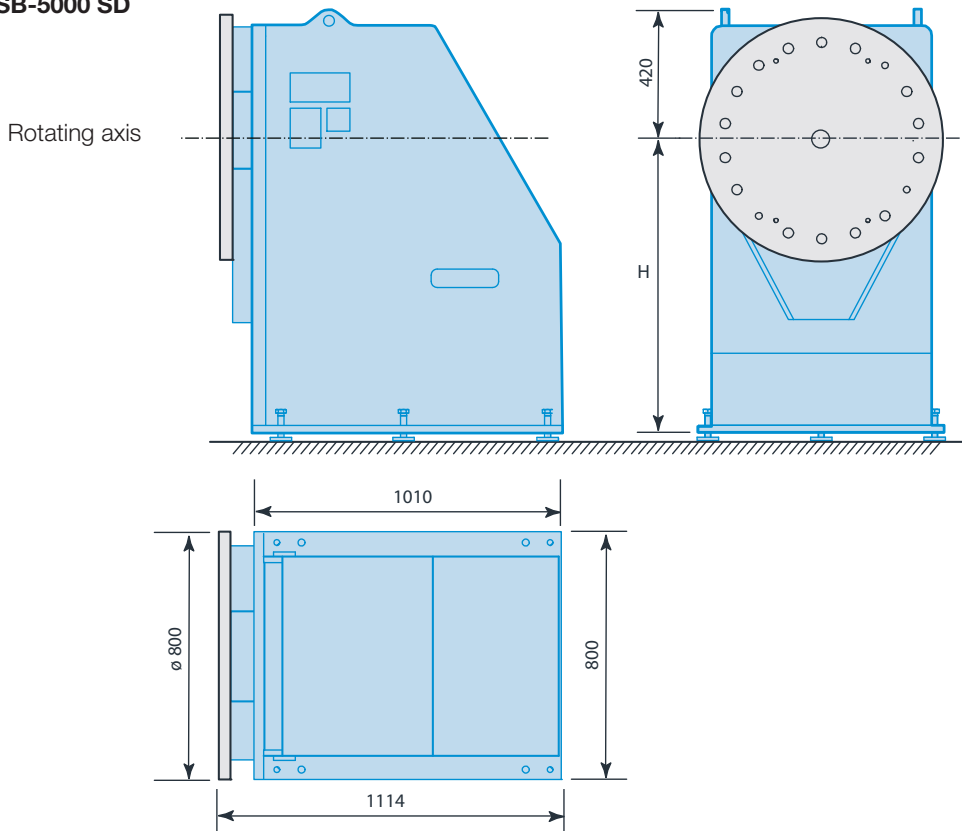

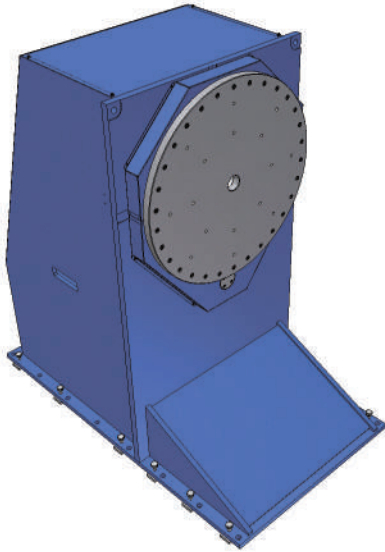

SPB

- Rigid design
- Supplementary tailstocks
- High load capacity

This is a one station positioner for workpieces requiring rotation about one axis.

To support long workpieces it is advisable to use a supplementary tailstock. The free standing SPB tailstock can be mounted directly on the floor at an appropriate distance from the positioner.

Available accessories

- Fixture brackets
- Tailstocks

Technical data		HSB-7000SD	HSB-10000SD	HSB-20000SD
Maximum payload	kg	7,000	10,000	20,000
Welding capacity, 100 % duty cycle	A	2 x 350	2 x 350	2 x 350 A
Welding capacity, 60 % duty cycle	A	2 x 460	2 x 460	2 x 460 A
Height to fixture disc's center (H)	mm	1200, 1500	1200-2100 ¹⁾	2100
<i>Rotating axis</i>				
Torque, dynamic	Nm	8290	15,058	18,060
Torque, static	Nm	6632	12,045	14,750
Rated offset from the center of gravity (COG)	mm	96	123	75
Rated speed	rpm	0-3.4	0-1.92	0-2.2
Maximum speed	rpm	9.1	2.5	4.4
Tailstock, free standing		SPB-7000	SPB-10000	--

¹⁾ 1200, 1500, 1660, 1830 and 2100 mm

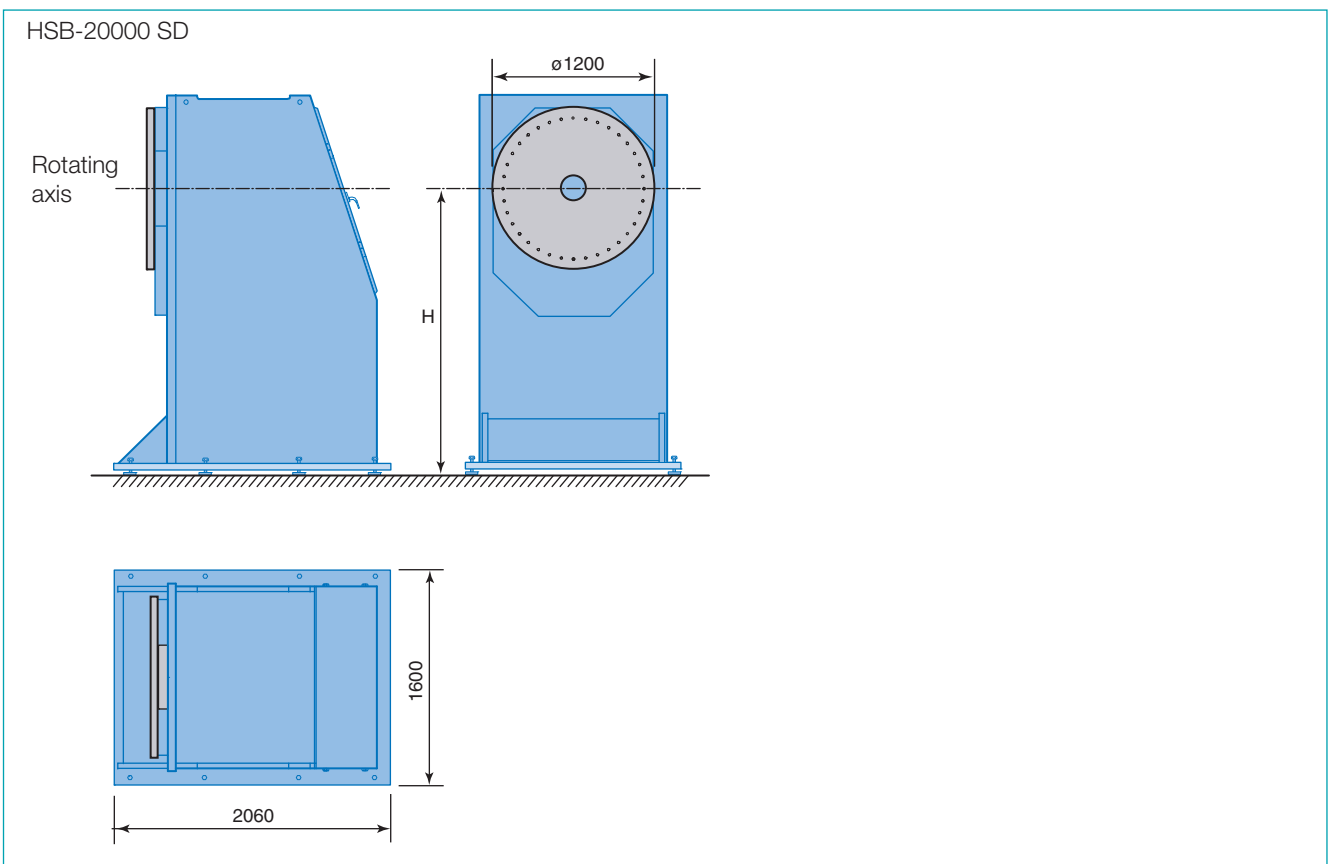
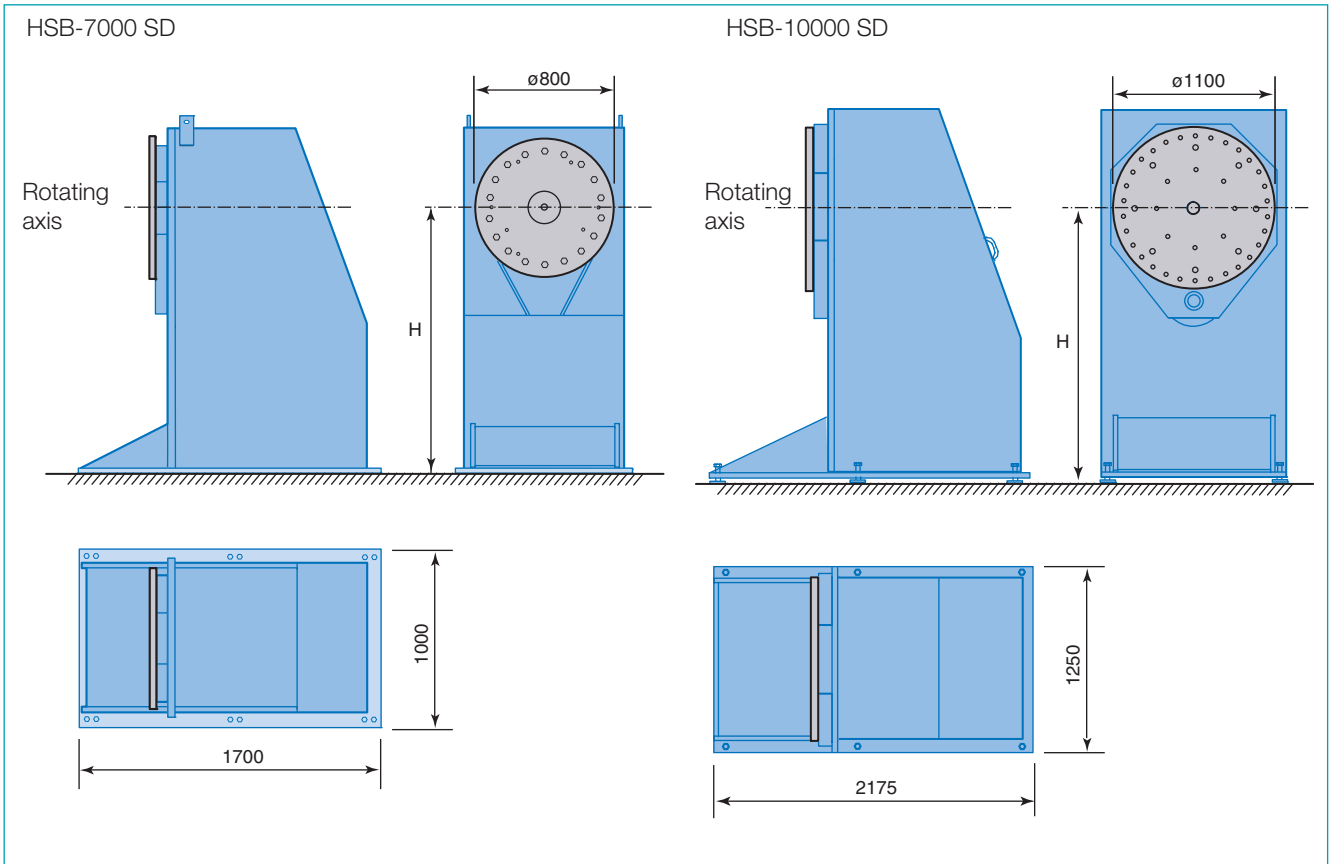

SPD

One axis positioner
1-station



- Manually adjusted centres
- Three sizes

This is tailstock, on a track with a dove-tail design available in three sizes for workpieces with a maximum diameter of 1500 mm

The distance between the fixture discs is adjustable as the tailstock can be moved by hand along the beam and secured in any position.

Technical data		SPD-500
Maximum payload	kg	500
Maximum fixture width, radius (R)	mm	750
Distance between fixture plates (A)	mm	0-2000, 0-2600, 0-3600
Total length (B)	mm	2400, 3000, 4000

SPD-500

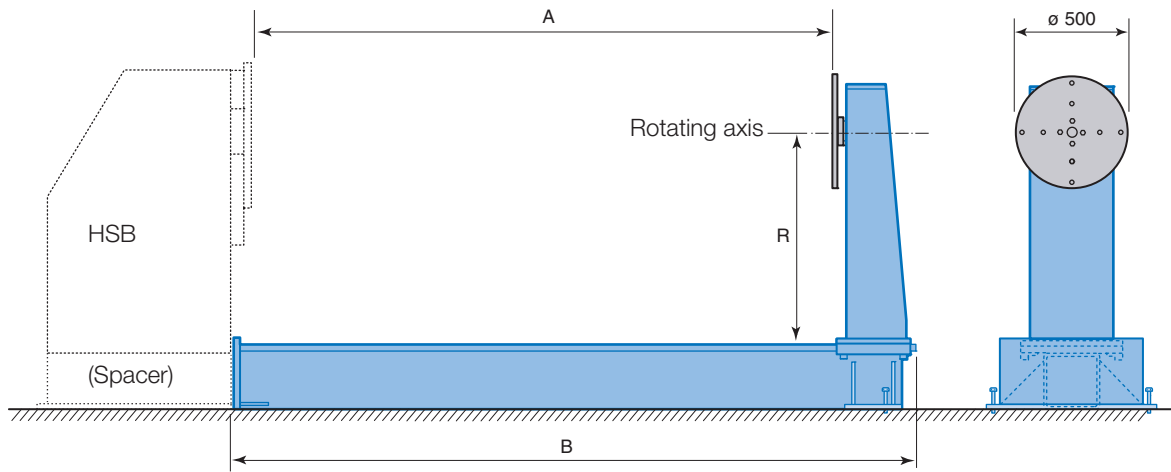

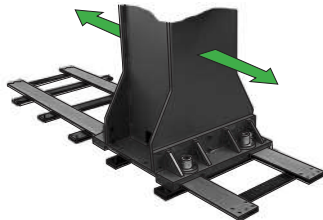

SPB-2000 on a rail track

- Rigid design
- Single or twin disc model
- Optional rail track

This is a tailstock for floor mounting at an appropriate distance from the positioner. The SPB-2000 is also available in a twin fixture model, with fixture discs on both sides.

The optional rail track for SPB-2000 makes it possible to move the tailstock by hand and fasten it anywhere along the track. The rail track can be made up to fifteen meters long.

Accessories

- Current transfer unit
- Shaft locking device
- Signal transfer unit

Technical data		SPB-2000 single	SPB-2000 twin	SPB-7000 single
Maximum fixture width, radius (R)	mm	970, 1200, 1500	970, 1200, 1500	1200, 1500, 1830
Current transfer unit		yes	yes	yes
Shaft locking device		yes ¹⁾	no	yes ¹⁾
Signal transfer unit		yes ²⁾	no	no

¹⁾ Cannot be combined with signal transfer unit

²⁾ Cannot be combined with shaft locking device or current transfer unit

SPB-2000, -7000

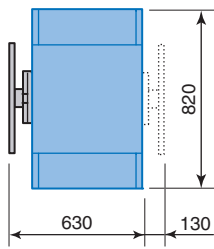
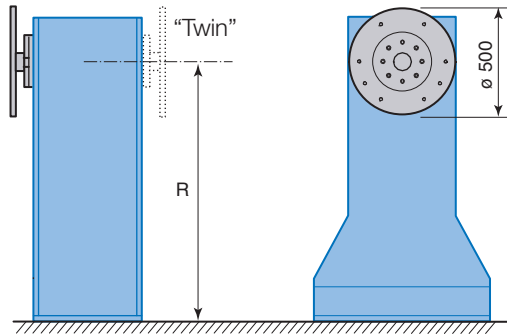

RM2...STN

One axis positioner
2-station

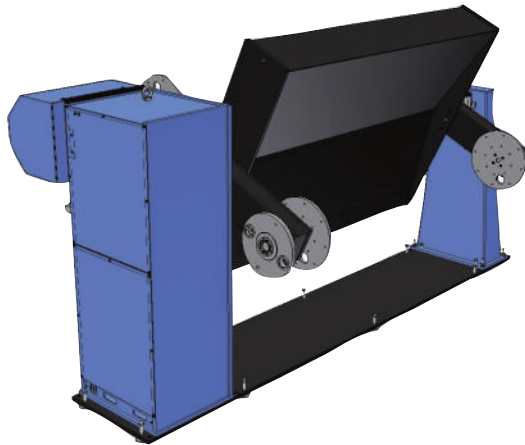

- Designed for operator ease of use
- Space saving design
- Patented single motor drive

This is a two station positioner for workpieces that require rotation about one axis. It has been designed for operator ease of use, with a suitable working height for loading/unloading the fixtures, and is delivered complete with an anti-glare shield.

The RM2-series has a space saving design due to its vertical station changing, and a patented single motor drive.

Available accessories

- Slip ring device
- Controlled air
- Fixture brackets

Technical data		RM2-250 STN	RM2-500 STN
Maximum payload, per station	kg	250	500
Welding capacity, 100 % duty cycle	A	700	700
Welding capacity, 60 % duty cycle	A	920	920
Distance between fixture plates (A)	mm	1600, 2000, 2636, 3000	1600, 2000, 2636, 3000 3500
Total length (B)	mm	A + 1645	A + 1818
Maximum fixture's width, diameter (D)	mm	1170	1350 1300
Air channels		2 x 1/4"	2 x 1/4"
<i>Index axis</i>			
Index time ¹⁾	sec	4	7
<i>Rotating axis</i>			
Torque, dynamic	Nm	1197	1197
Torque, static	Nm	957	957
Rated speed	rpm	0-16.8	0-16.8
Rated offset from the center of gravity (COG)	mm	390	194

¹⁾ Including the 180° rotating of the fixture

RM2-250 STN

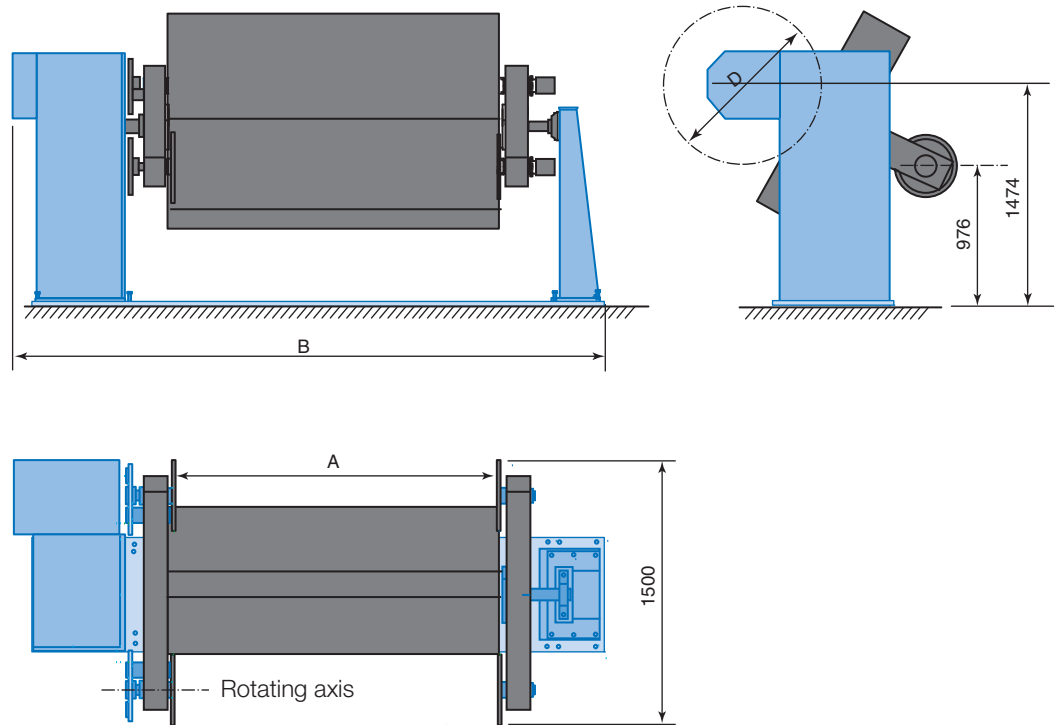

RM2-500 STN

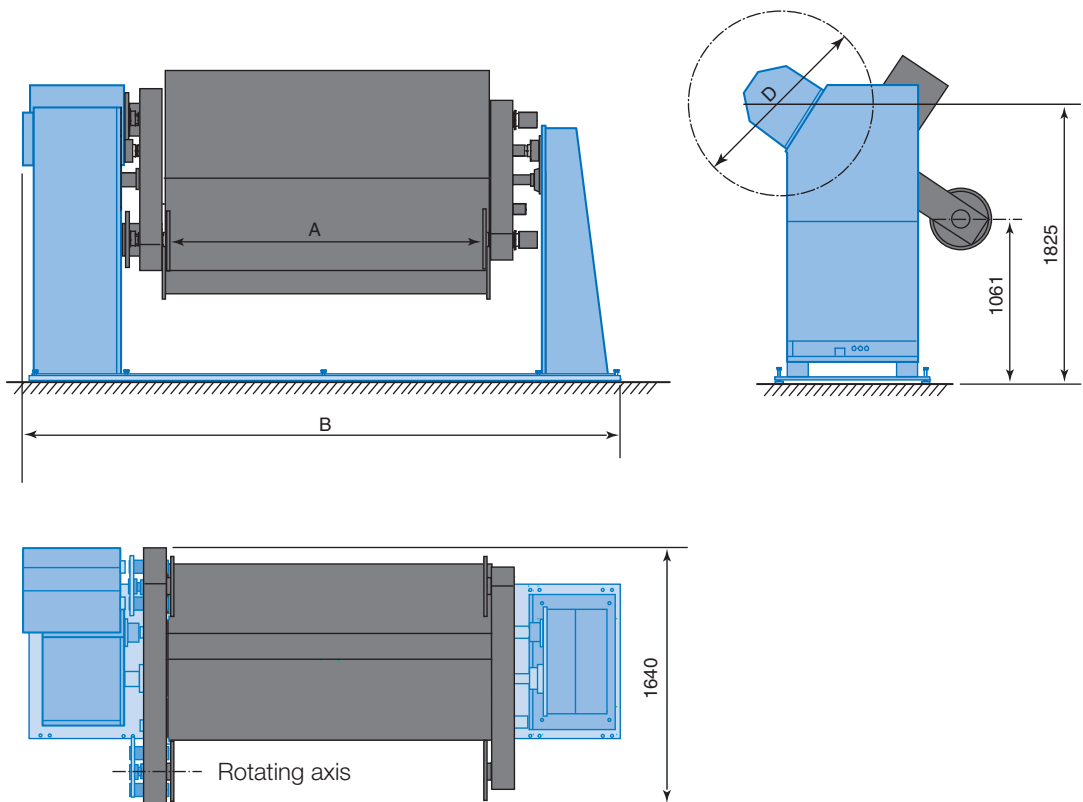

RM2...TN

One axis positioner
2-station



- Designed for operator ease-of-use
- Space saving design
- Patented single motor drive

This is a two station positioner for workpieces that require rotation about one axis. It is delivered complete with an anti-glare shield. The positioner is placed on a foundation which gives the operator a suitable working height for loading/unloading.

During assembly it is possible to connect the robot stand(s) to the positioner so that it is possible to dismount and reassemble the station without losing the robot's reference points. The whole station can be moved with a large fork lift.

Available accessories

- Slip ring device
- Controlled air
- Fixture brackets

Technical data		RM2-500 TN	RM2-750 TN
Maximum payload, per station	kg	500	750
Welding capacity, 100 % duty cycle	A	700	700
Welding capacity, 60 % duty cycle	A	920	920
Distance between fixture plates (A)	mm	2000-3500 ¹⁾	2000-3500 ¹⁾
Total length (B)	mm	A + 1790	A + 1790
Maximum fixture width, diameter (D)	mm	1200 ²⁾	1200 ²⁾
Air channels		2 x 1/4"	2 x 1/4"
<i>Index axis</i>			
Index time	sec	6.5	7.5
<i>Rotating axis</i>			
Torque, dynamic	Nm	2165	2165
Torque, static	Nm	1732	1732
Rated speed	rpm	0-28.4	0-28.4
Rated offset from the center of gravity (COG)	mm	350	235

¹⁾ 2000, 2636, 3000 and 3500 mm

²⁾ 1000 mm for fixture width 3500 mm

RM2-500 TX, RM2-750 TN

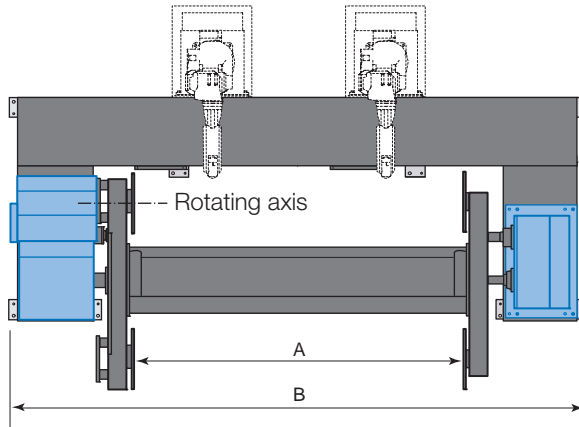
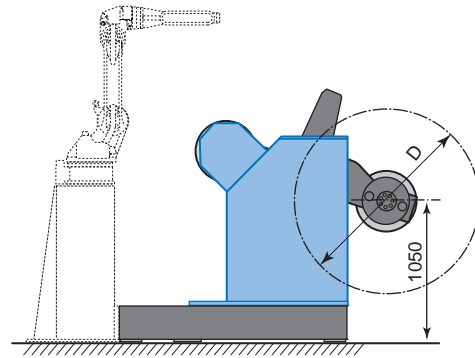
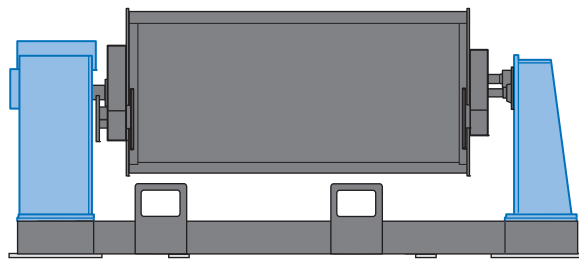

RM2...S3D

One axis positioner
2-station



- Designed for operator ease of use
- Space saving design
- Ergonomic working height

This is a two station positioner for workpieces that require rotation about one axis. It has been designed for operator ease of use, with a suitable working height for loading/unloading the fixtures, and is delivered with an anti-glare shield. The positioner has three servo motors which makes it possible to maintain the position of the fixture during rotation.

Available accessories

- Slip ring device
- Controlled air
- Fixture brackets

Technical data		RM2-250 S3D	-500 S3D	-750 S3D
Maximum payload, per station	kg	250	500	750
Welding capacity, 100 % duty cycle	A	2 x 350 A	2 x 350 A	2 x 350 A
Welding capacity, 60 % duty cycle	A	2 x 460 A	2 x 460 A	2 x 460 A
Distance between fixture plates (A)	mm	1600, 2000	2000-4000 ¹⁾	2000-4000 ¹⁾
Total length (B)	mm	A + 1510	A + 1510	A + 1510
Air channels		1 x 1/2"		
	<i>Index axis</i>			
Index time	sec	3.5	3.5	4.0
	<i>Rotating axis</i>			
Torque, dynamic	Nm	393	1330	1330
Torque, static	Nm	314	1063	1063
Rated speed	rpm	0-22.5	0-10.7	0-10.7
Rated offset from the center of gravity (COG)	mm	128	217	144

¹⁾ 2000, 2636, 3000, 3500, 4000, (4500) mm

RM2-250 S3D, RM2-500 S3D, RM2-750 S3D

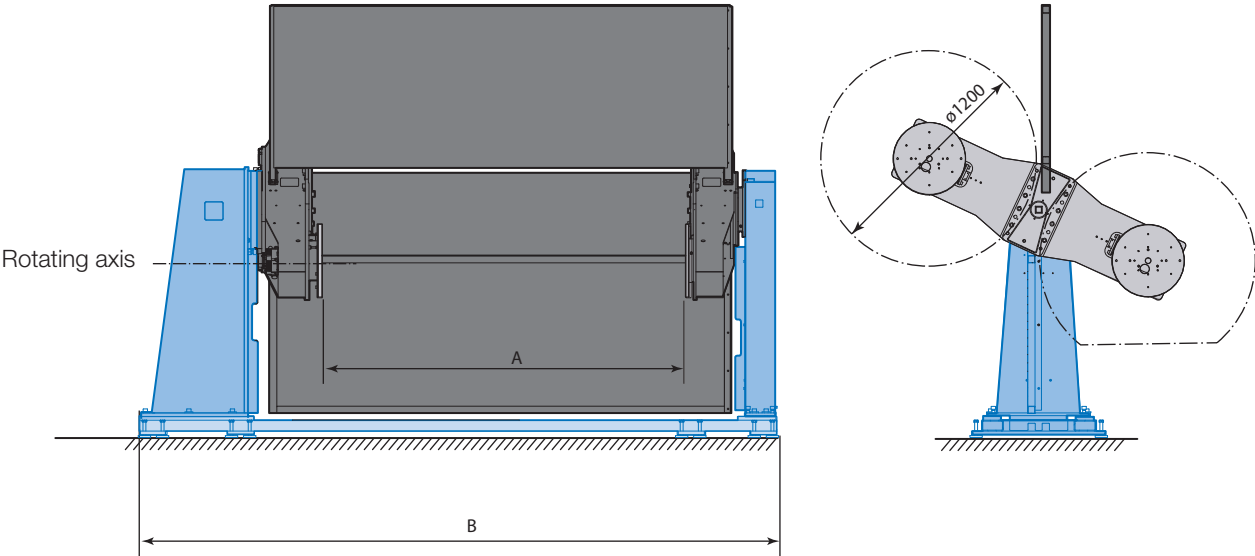

Technical data may be subject to change without previous notice
© YASKAWA Nordic AB · Reg No. 1007EN-00 · 2012-08

RM2...S3D

One axis positioner
2-station

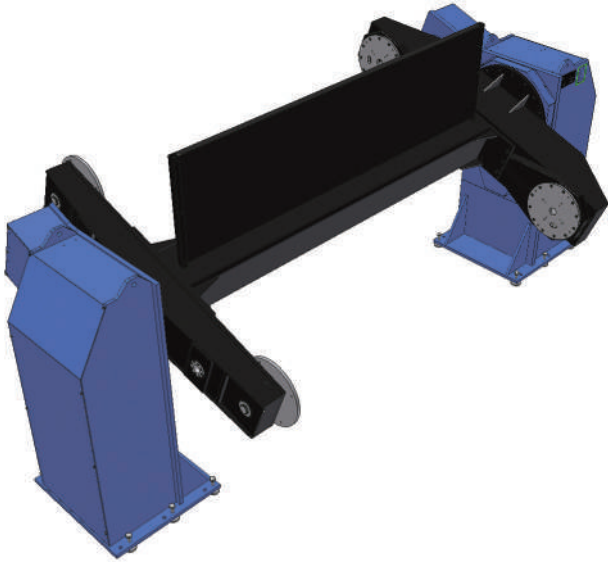

- Designed for operator ease of use
- Space saving design
- Ergonomic working height

This is a two station positioner for workpieces that require rotation about one axis. It has been designed for operator ease of use, with a suitable working height for loading/unloading the fixtures, and is delivered with an anti-glare shield (not shown in the picture). The positioner has three servo motors which makes it possible to maintain the position of the fixture during rotation.

Available accessories

- Slip ring device
- Controlled air
- Fixture brackets

Technical data		RM2-1000 S3D
Maximum payload, per station	kg	1000 kg
Welding capacity, 100 % duty cycle	A	2 x 350 A
Welding capacity, 60 % duty cycle	A	2 x 460 A
Distance between fixture plates (A)	mm	2000-6500 ¹⁾
Total length (B)	mm	A + 1142
Air channels		1 x 1/2"
	<i>Index axis</i>	
Index time	sec	5
	<i>Rotating axis</i>	
Torque, dynamic	Nm	2600
Torque, static	Nm	2080
Rated speed	rpm	0-15
Rated offset from the center of gravity (COG)	mm	212

¹⁾ 2000, 2636, 3000, 3500, 4000, 4500, 5000, 5500, 6000 and 6500 mm

RM2-1000 S3D

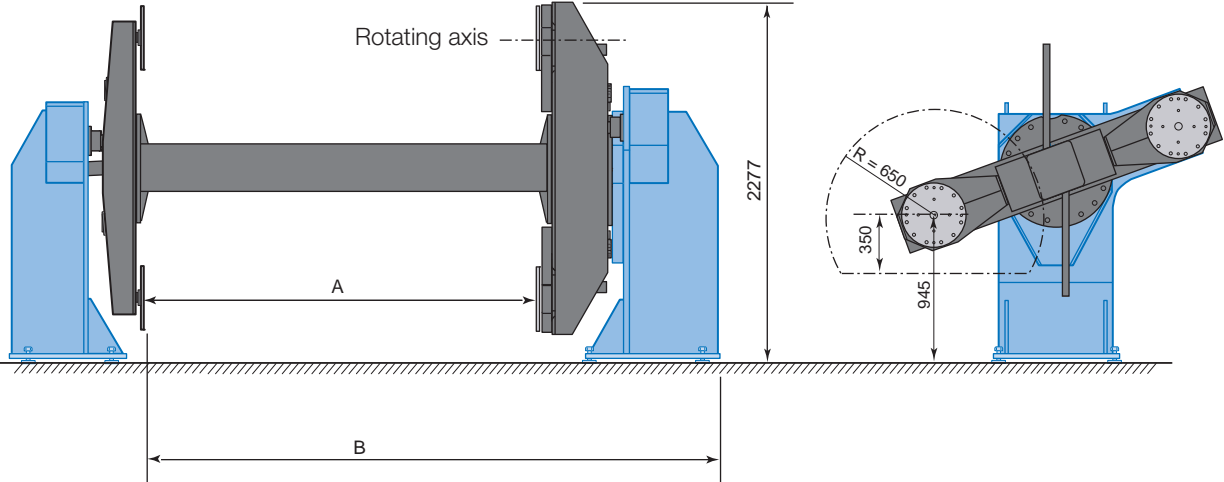

Technical data may be subject to change without previous notice
© YASKAWA Nordic AB · Reg No. 1025EN-02 · 2012-03

VMH...CDD

One axis positioner
2-station

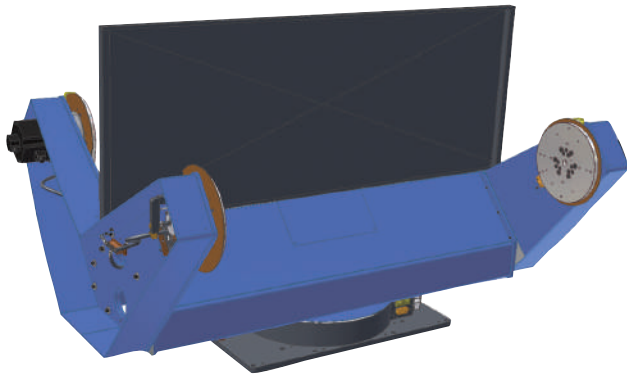

- Designed for operator ease of use
- Direct drive
- Compact, space saving design

This is a two station positioner for workpieces that require rotation about one axis. It has been designed for operator ease of use, with a suitable working height for loading/unloading the fixtures, and is delivered complete with an anti-glare shield.

Available accessories

- Slip ring device
- Controlled air
- Fixture brackets

Technical data		VMH-500 CDD		
Maximum payload, per station	kg	500		
Welding capacity, 100 % duty cycle	A	2 x 350		
Welding capacity, 60 % intermittent	A	2 x 460		
Distance between fixture plates (A)	mm	1600	2000	2636
Maximum fixture width, diameter (C)	mm	ø 1300	ø 1300	ø 1300
Maximum diameter (D)	mm	ø 3160	ø 3360	ø 3800
<i>Index axis</i>				
Torque, dynamic	Nm	2237	2237	2237
Index time	sec	3	3	3.5
<i>Rotating axis</i>				
Torque, dynamic	Nm	1330		
Torque, static	Nm	1063		
Rated speed	rpm	0-10.6		
Maximum speed	rpm	28.4		
Rated offset from the center of gravity (COG)	mm	216		

VMH-500 CDD

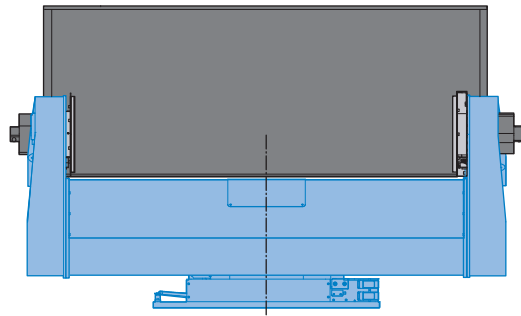

Index axis

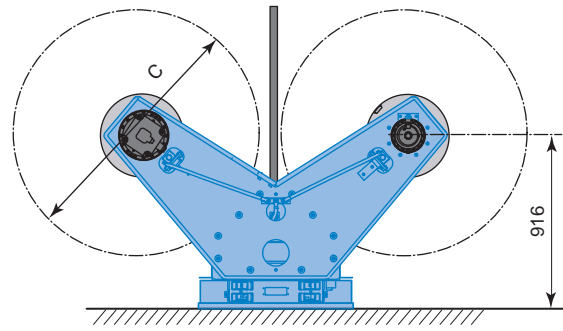

916

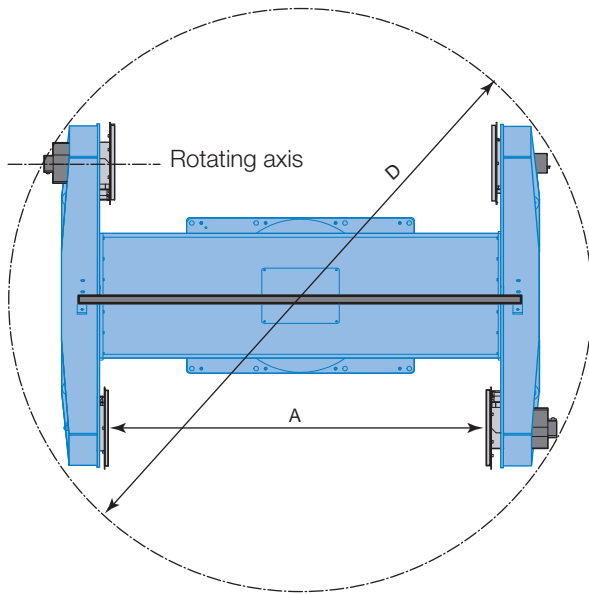

Rotating axis

A

D

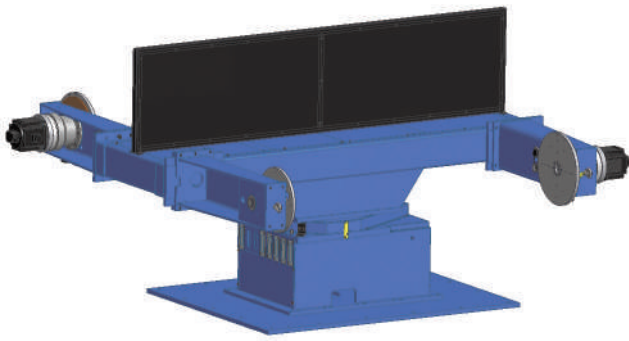

- Rigid rotating base
- Different lengths between fixture plates
- Ideal working height

This is a two station positioner for workpieces that require rotation about one axis. It has been designed for operator ease of use, with a suitable working height for loading/unloading the fixtures, and is delivered complete with an anti-glare shield.

Suitable for workpieces with diameters up to 1800 mm.

Available accessories

- Slip ring device
- Controlled air
- Fixture brackets

Technical data		VMH-250 S3N	VMH-500 S3N			
Maximum payload, per station	kg	250	500			
Welding capacity, 100 % duty cycle	A	350	2 x 350			
Welding capacity, 60 % duty cycle	A	460	2 x 460			
Distance between fixture plates (L)	mm	1600, 2000	2000	2000	2500	3000
Maximum fixture's width, diameter (D)	mm	1000	1000	1300	1300	1700
<i>Index axis</i>						
Torque, dynamic	Nm	1879	6055	6055	6055	6055
Index time	sec	4	6	6	6	6
<i>Rotating axis</i>						
Torque, dynamic	Nm	1198	1198			
Torque, static	Nm	958	958			
Rated speed	rpm	0-12.4	0-12.4			
Maximum speed	rpm	25.2	25.2			
Rated offset from the center of gravity (COG)	mm	390	195			

VMH-250 S3N

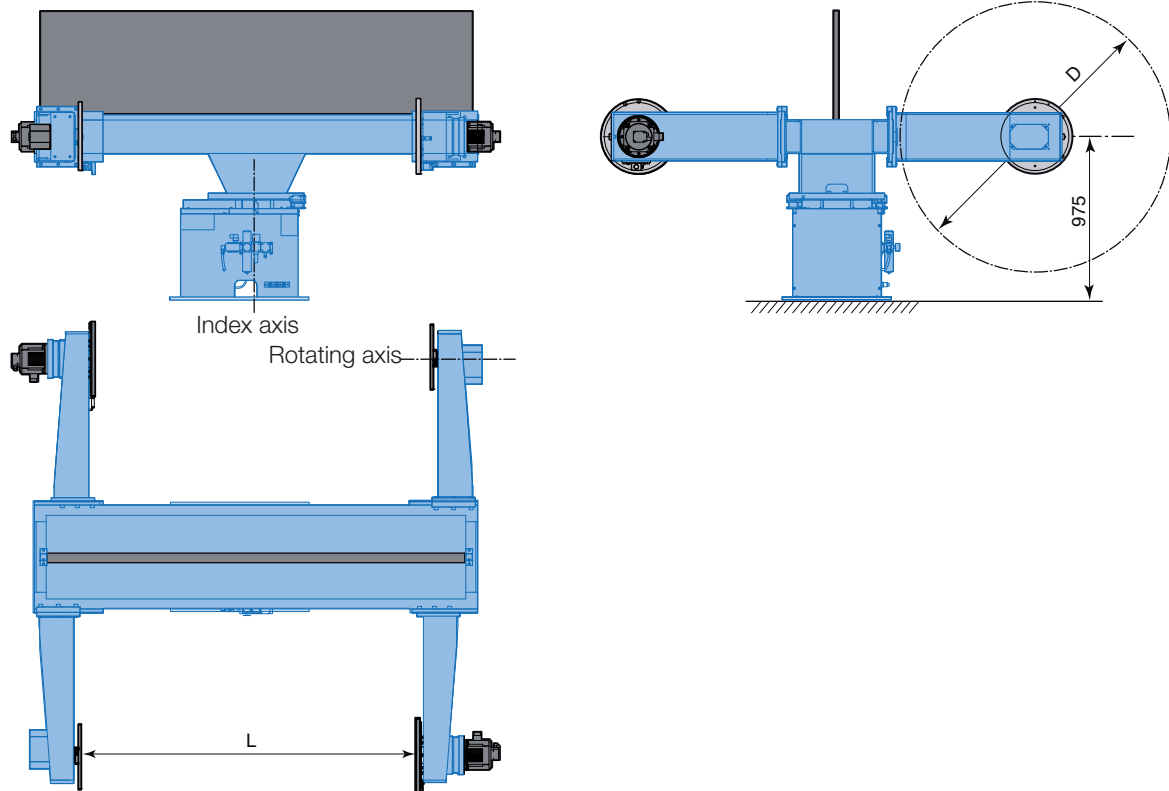

VMH-500 S3N

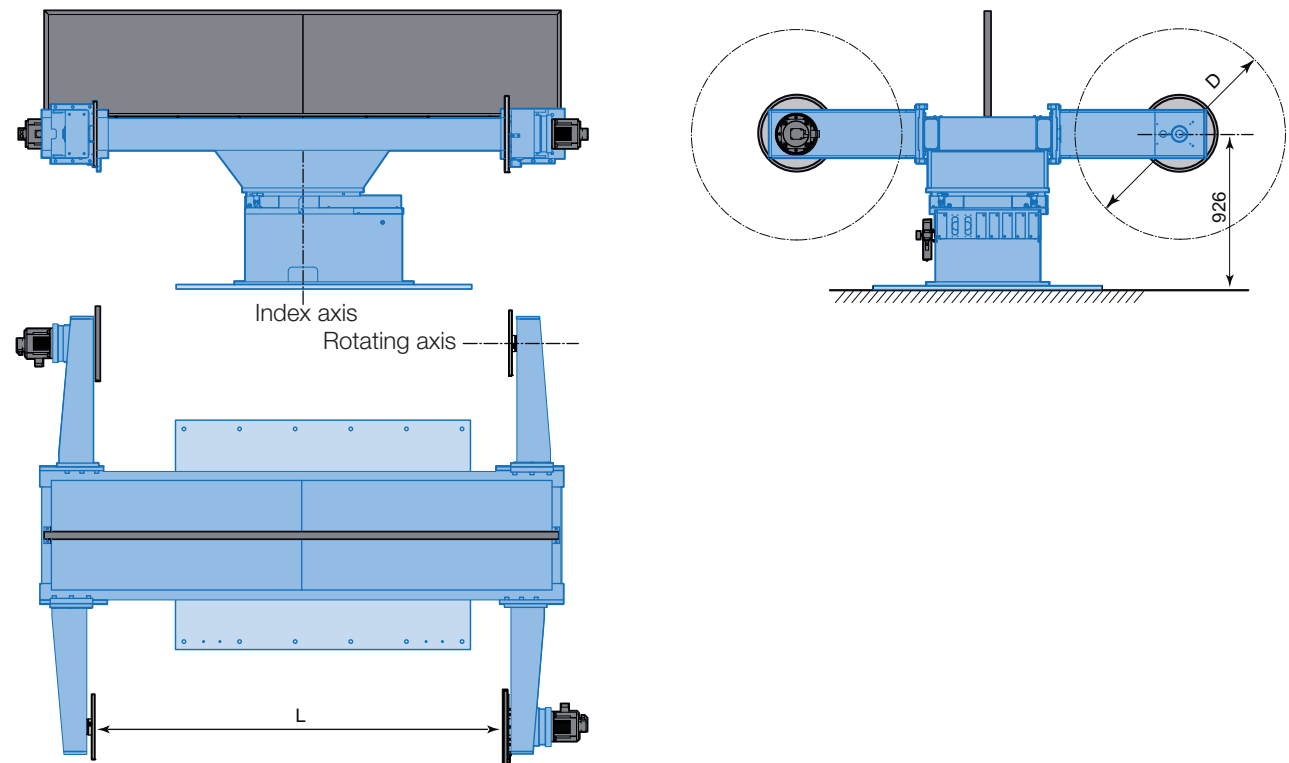

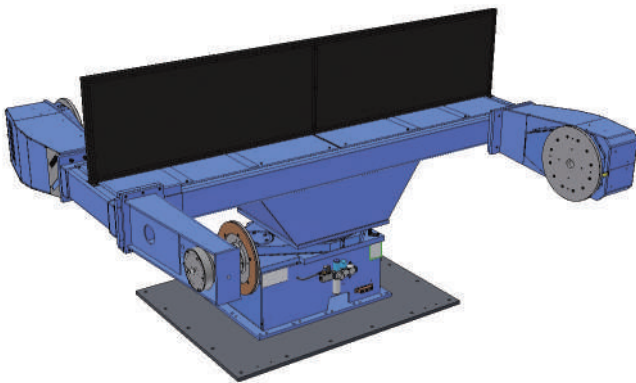

- Rigid design
- Ideal working height
- Heavy duty

This is a two station positioner for workpieces that require rotation about one axis. It has been designed for operator ease of use, with a suitable working height for loading/unloading the fixtures, and is delivered complete with an anti-glare shield.

Suitable for workpieces with diameters up to 2000 mm.

Available accessories

- Slip ring device
- Controlled air
- Fixture brackets

Technical data		VMH-1000 S3N	
Maximum payload, per station	kg	1000	
Welding capacity, 100 % duty cycle	A	2 x 350	
Welding capacity, 60 % intermittent	A	2 x 460	
Distance between fixture plates (L)	mm	2000	2500
Maximum fixture width, diameter (D)	mm	1500	1500
Height (H)	mm	1076	1316
<i>Index axis</i>			
Torque, dynamic	Nm	6055	
Index time	sec	6	
<i>Rotating axis</i>			
Torque, dynamic	Nm	2830	
Torque, static	Nm	2264	
Rated speed	rpm	0-8.4	
Rated offset from the center of gravity (COG)	mm	230	

VMH-1000 S3N

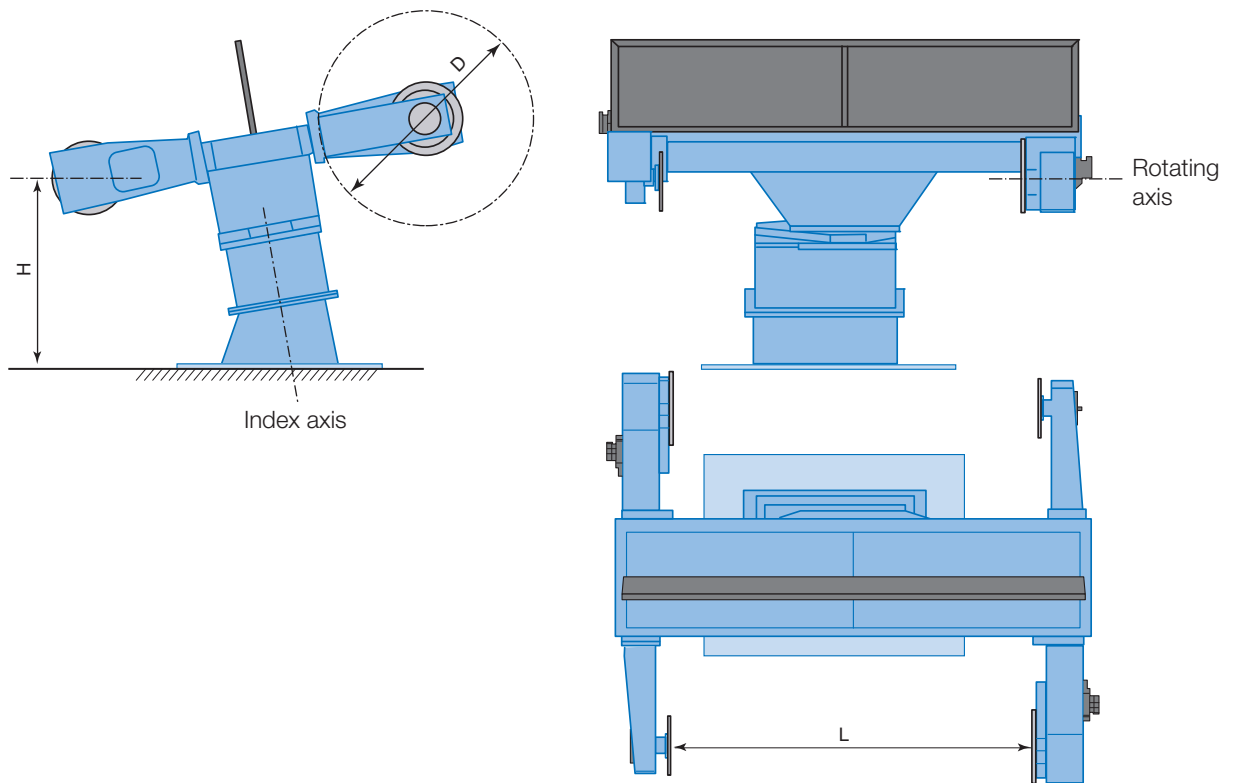

MT1

Two axes positioner
1-station

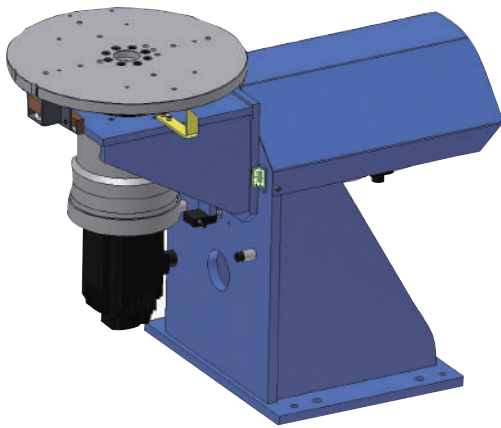

- Space saving design
- Direct drive
- Tilt and Rotate positioner

This is a one station tilt-rotate positioner for workpieces requiring rotation about two axes. Due to its compact and space saving design, it is suitable for integration in e.g. compact welding stations.

The fixture disc can be tilted in synchronisation with the robot, $\pm 90^\circ$.

Option

- Spacer (H = 170 or 270 mm)

Technical data		MT1-250 S2D
Maximum payload	kg	250
Welding capacity, 100 % duty cycle	A	350
Welding capacity, 60 % duty cycle	A	460
<i>Tilt axis</i>		
Torque, dynamic	Nm	1108
Torque, static	Nm	886
Rated speed	rpm	0-12.6
Maximum speed	rpm	25.2
Maximum offset (from tilt axis)	mm	361
<i>Rotating axis</i>		
Torque, dynamic	Nm	1046
Torque, static	Nm	837
Rated speed	rpm	0-9.8
Maximum speed	rpm	26.1
Rated offset from the center of gravity (COG)	mm	275

MT1-250 S2D

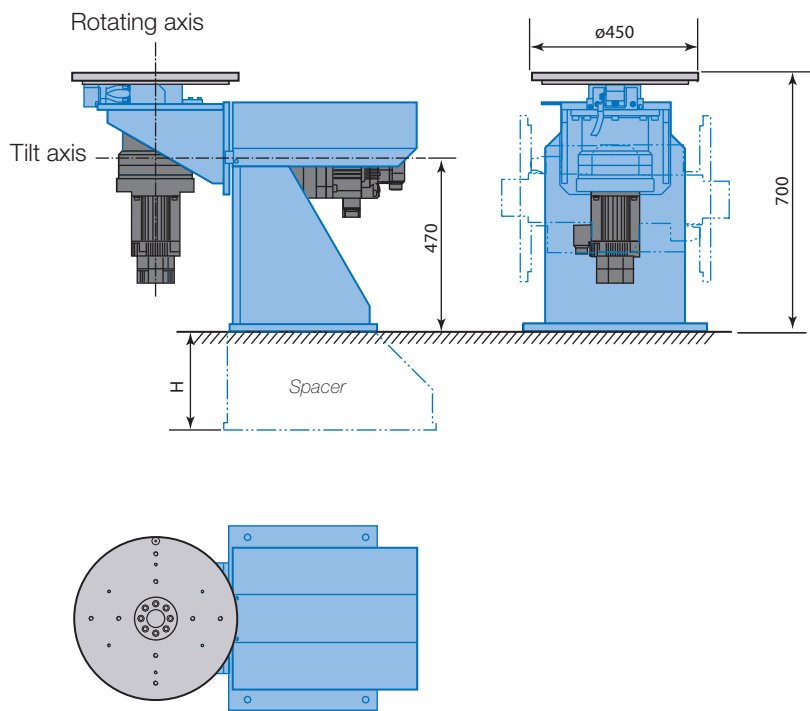

MT1

Two axes positioner
1-station

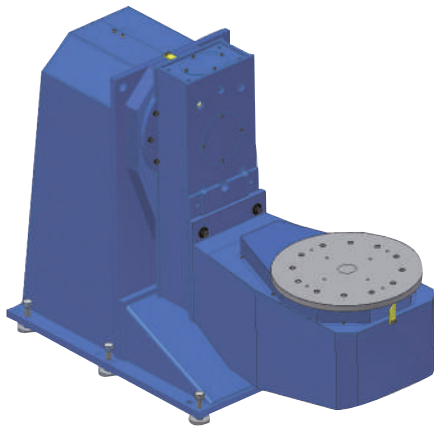

- Rigid design
- High freedom of positioning
- For heavy workpieces

This is a one station positioner for workpieces requiring rotation about two axes. Its high freedom of positioning makes it easy to find the optimum position even in complicated workpieces.

This MT1 positioner is designed to withstand the strain of handling heavy workpieces.

Technical data		MT1-500 S2DL	MT1-750 S2DL			
Maximum payload	kg	500	750			
Welding capacity, 100 % duty cycle	A	2 x 350	2 x 350			
Welding capacity, 60 % duty cycle	A	2 x 460	2 x 460			
Height (H)	mm	850	650	650	850	850
Arm length (L)	mm	850	600	750	600	750
		<i>Tilt axis</i>				
Torque, dynamic	Nm	2600	2600			
Torque, static	Nm	2080	2080			
Rated speed	rpm	0-5.3	0-5.3			
Maximum speed	rpm	15	15			
Maximum offset (from tilt axis)	mm	--	--			
		<i>Rotating axis</i>				
Torque, dynamic	Nm	2600	2600			
Torque, static	Nm	2080	2080			
Rated speed	rpm	0-5.3	0-5.3			
Maximum speed	rpm	15	15			
Rated offset from the center of gravity (COG)	mm	424	283			

MT1-500 S2DL, MT1-750 S2DL

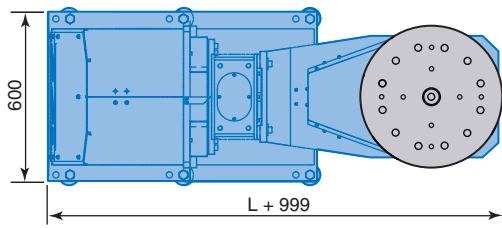
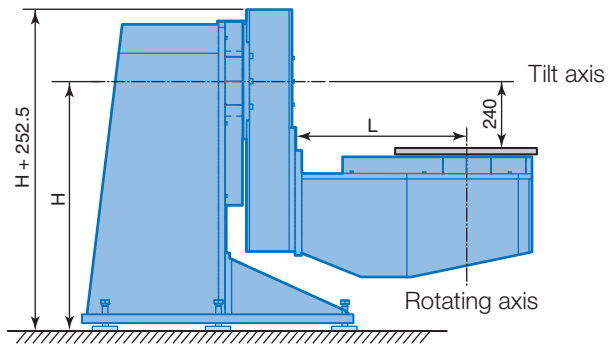

MT1

Two axes positioner
1-station

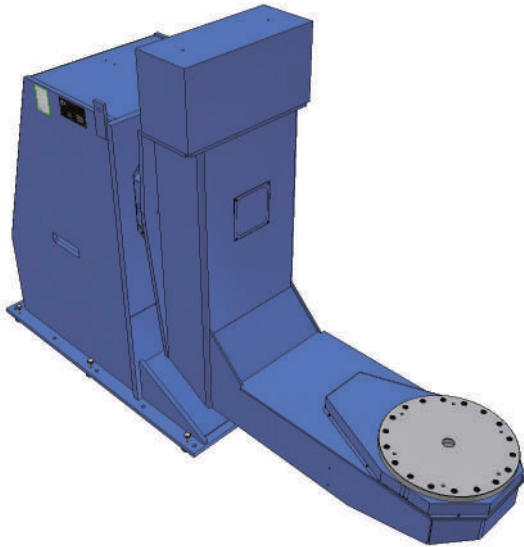

- Rigid design
- High freedom of positioning

This is a one station positioner for workpieces requiring rotation about two axes. Its high freedom of positioning makes it easy to find the optimum position even in complicated workpieces.

The MT1 positioner is designed to withstand the strain of heavy payloads. When used together with a MOTOMAN Gantry robot it provides the best possible workpiece access.

Technical data		MT1-1000 S2D		MT1-1500 S2D	
Maximum payload	kg	1000		1500	
Welding capacity, 100 % duty cycle	A	2 x 350		2 x 350	
Welding capacity, 60 % duty cycle	A	2 x 460		2 x 460	
Height (H)	mm	970	1200	1200	1500
Arm length (L)	mm	850	1100	1195	1615
	<i>Tilt axis</i>				
Torque, dynamic	Nm	4236		8290	
Torque, static	Nm	3389		6632	
Rated speed	rpm	0-3.6		0-3.4	
Maximum speed	rpm	9.6		9.1	
	<i>Rotating axis</i>				
Torque, dynamic	Nm	2830		6480	
Torque, static	Nm	2264		5184	
Rated speed	rpm	0-5,3		0-4.3	
Maximum speed	rpm	15		11.6	
Rated offset from the center of gravity (COG)	mm	230		352	

MT1

Two axes positioner
1-station

MT1-1000 S2D

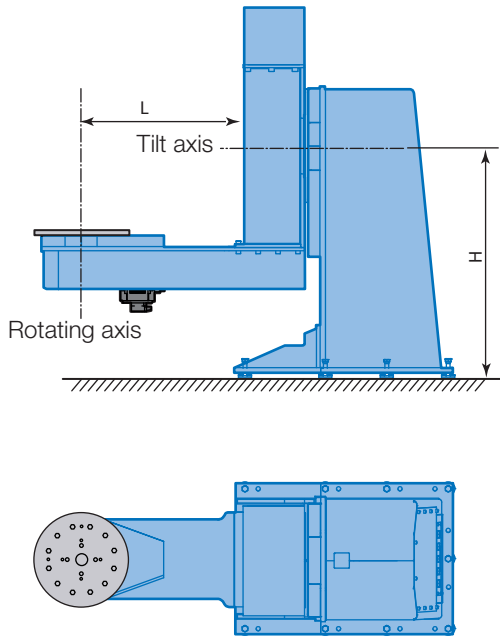

MT1-1500 S2D (H = 1200)

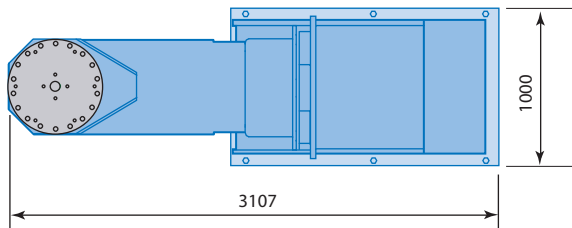
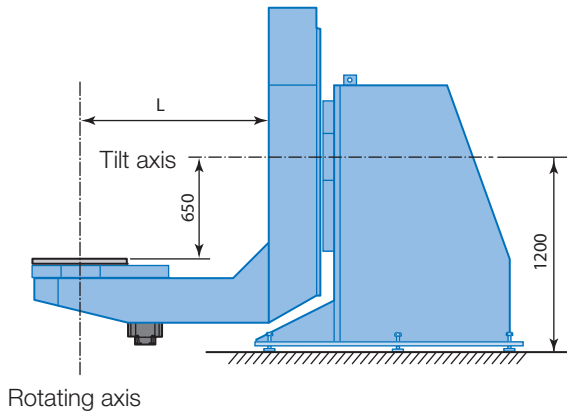

MT1-1500 S2D (H = 1500)

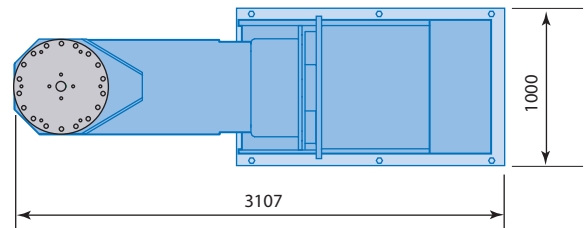
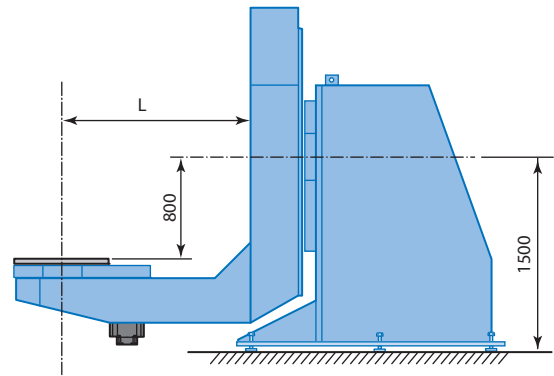

MT1

Two axes positioner
1-station

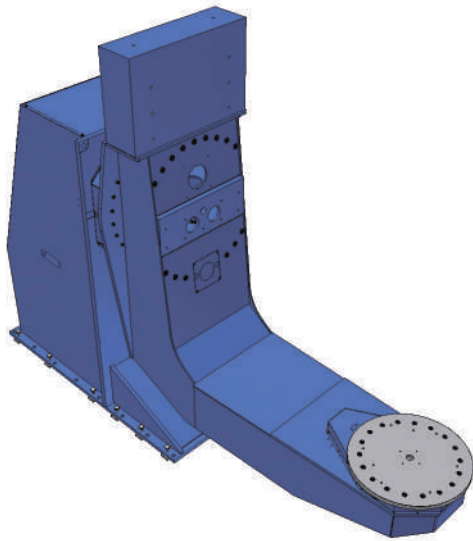

- Rigid design
- Suitable for heavier parts
- High freedom of positioning

This is a one station positioner for workpieces requiring rotation about two axes. Its high freedom of positioning makes it easy to find the optimum position even in complicated workpieces.

The MT1 positioner is designed to withstand the strain of heavy payloads. When used together with a MOTOMAN Gantry robot it provides the best possible workpiece access.

Technical data		MT1-3000 S2D	MT1-5000 S2D
Maximum payload	kg	3000	5000
Welding capacity, 100 % duty cycle	A	2 x 350	2 x 350
Welding capacity, 60 % duty cycle	A	2 x 460	2 x 460
<i>Tilt axis</i>			
Torque, dynamic	Nm	15058	15058
Torque, static	Nm	12045	12045
Rated speed	rpm	0-1.9	0-1.9
Maximum speed	rpm	2.5	2.5
<i>Rotating axis</i>			
Torque, dynamic	Nm	10498	10498
Torque, static	Nm	8398	8398
Rated speed	rpm	0-2.7	0-2.7
Maximum speed	rpm	3.6	3.6
Rated offset from the center of gravity (COG)	mm	285	171

MT1-3000 S2D

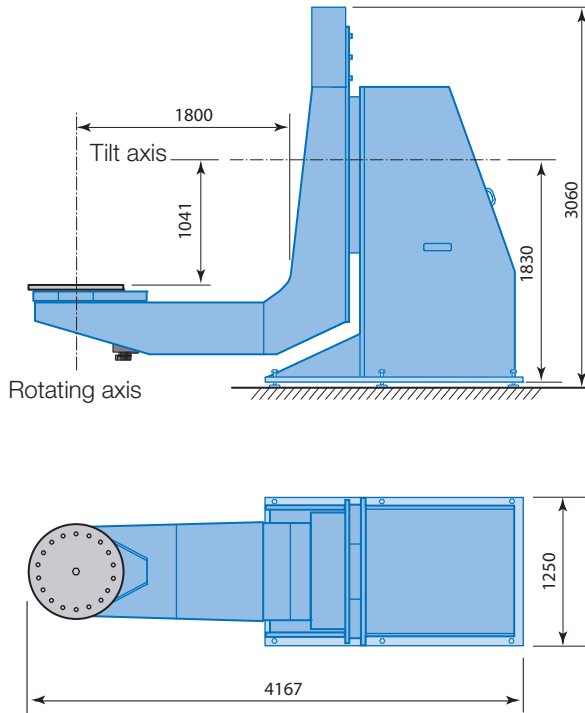

MT1-5000 S2D

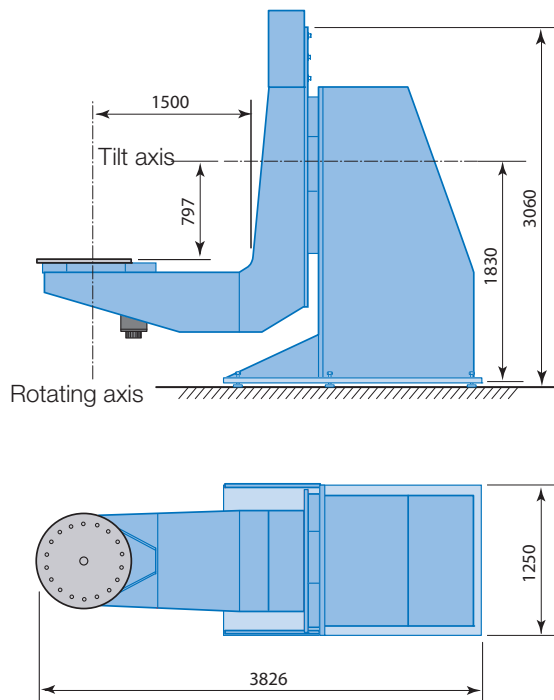

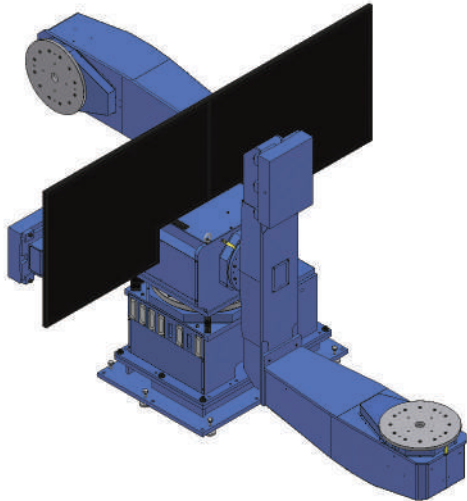

- High freedom of positioning
- Horizontal station changing

This is a two station positioner for workpieces requiring rotation about two axes. It is possible for the operator to load/unload the fixture during welding. It is delivered complete with an anti-glare shield. The distance between the fixture plates can be adjusted within the range (A) shown in the table below.

The VMF-series has a horizontal station changing.

Available accessories

- Slip ring device
- Controlled air
- Fixture brackets

Technical data		VMF-500 S5DL	VMF-7505DL
Maximum payload, per station	kg	500	750
Welding capacity, 100 % duty cycle	A	2 x 350	2 x 350
Welding capacity, 60 % duty cycle	A	2 x 460	2 x 460
Maximum radius (r)	mm	850, 1000, 1100	750
<i>Index axis</i>			
Torque,	Nm	6080	6080
Station index time	sec	6-8	6-8
Rated speed	rpm	0-8.7	0-8.7
<i>Tilt axis</i>			
Torque, dynamic	Nm	3166	3166
Torque, static	Nm	2533	2533
Rated speed	rpm	0-8.5	0-8.5
Rated offset from the center of gravity (COG)	mm	516	340
<i>Rotating axis</i>			
Torque, dynamic	Nm	2600	2600
Torque, static	Nm	2080	2080
Rated speed	rpm	0-8.8	0-8.8
Rated offset from the center of gravity (COG)	mm	424	282

VMF-500 S5DL, VMF-750 S5DL

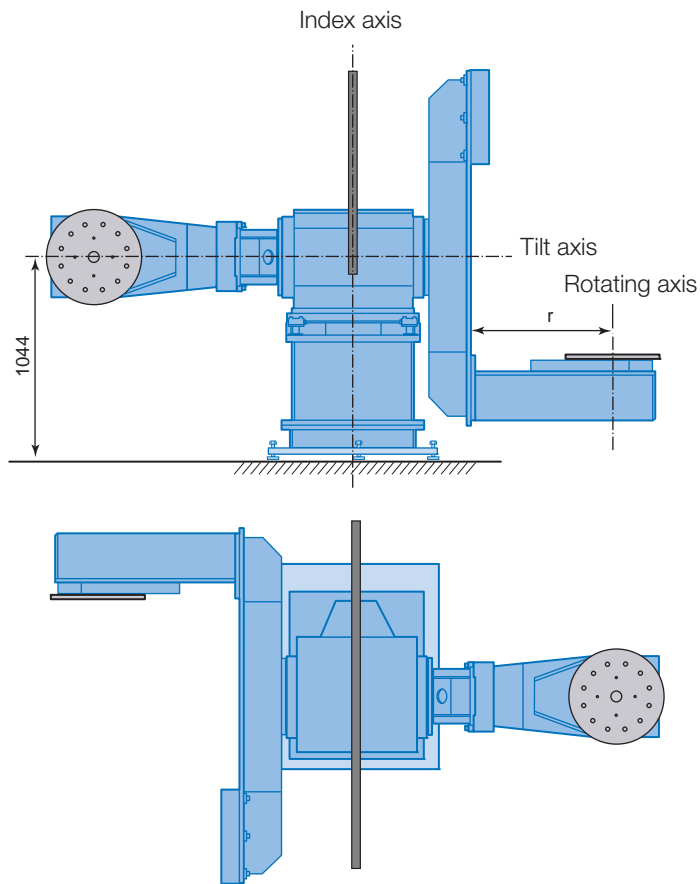

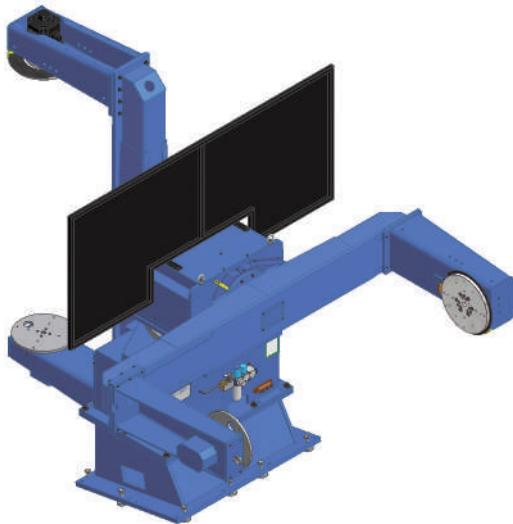

- High freedom of positioning
- Horizontal station changing

This is a two station positioner for workpieces requiring rotation about two axes. It is possible for the operator to load/unload the fixture during welding. It is delivered complete with an anti-glare shield. The distance between the fixture plates can be adjusted within the range (L) shown in the table below.

Available accessories

- Slip ring device
- Controlled air
- Fixture brackets

Options

- 10° or 15° tilted stand

Technical data		VMF-500 S5D	VMF-750 S5D
Maximum payload, per station	kg	500	750
Welding capacity, 100 % duty cycle	A	2 x 350	2 x 350
Welding capacity, 60 % duty cycle	A	2 x 460	2 x 460
Distance between fixture plates (L)	mm	1500-3000 ¹⁾	1500-3300 ²⁾
<i>Index axis</i>			
Torque, dynamic	Nm	6055	6055
Index time	sec	6-8	6-8
Maximum speed	rpm	0-10.0	0-10.0
<i>Tilt axis</i>			
Torque, dynamic	Nm	3166	3166
Torque, static	Nm	2533	2533
Maximum speed	rpm	0-8.5	0-8.5
Rated offset from the center of gravity (COG)	mm	510	340
<i>Rotating axis</i>			
Torque, dynamic	Nm	952	1330
Torque, static	Nm	762	1064
Maximum speed	rpm	0-35	0-30
Rated offset from the center of gravity (COG)	mm	155	144

¹⁾ 1500-2000, 2000-2500, 2500-3000 mm

²⁾ 1500-2000, 2000-2500, 2500-3000, 2800-3300 mm

VMF-500 S5D, VMF-750 S5D

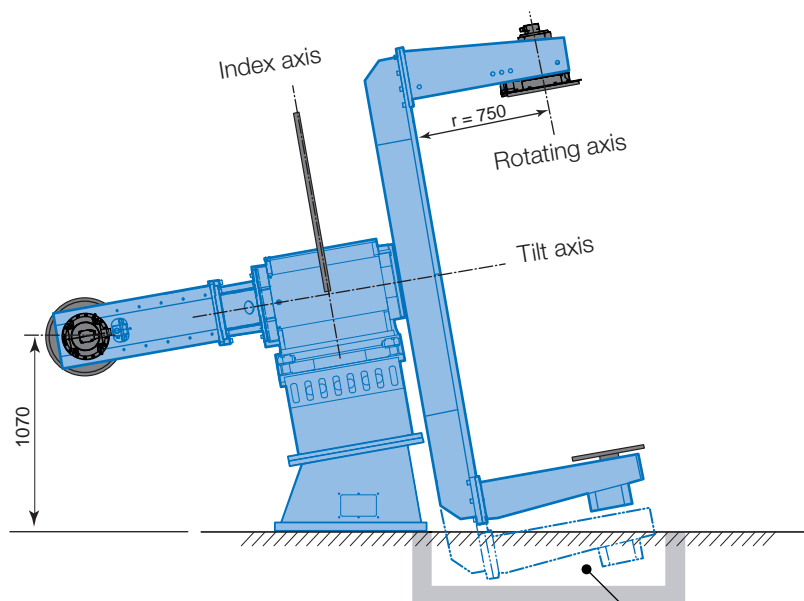

For models with a distance between the fixture plates (L) of 2000-2500 mm or more, this is a possible solution in order to fully rotate the arms.

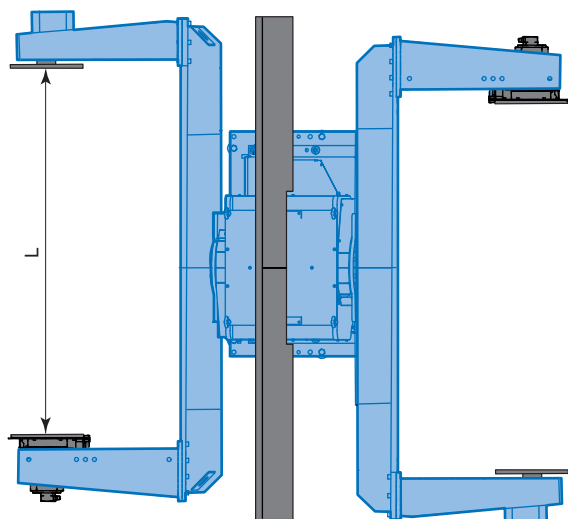

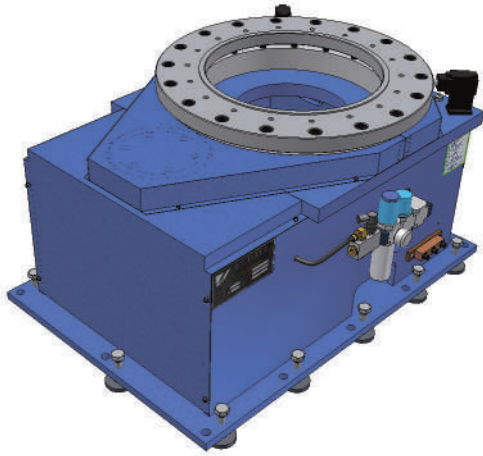

- Rotating base (for tailor-made positioners)
- Endless rotation
- Maintenance free operation

The VMS rotating module is normally used as a base in more complicated two station positioners or turning tables. Due to its simple design, with few mechanical parts, it provides maintenance free operation even with high payloads. The sleeve bearings makes endless rotation possible.

Cables and hoses are fed into the fixture from a hole in the center of the fixture disc.

The VMS rotating module is available in two sizes for payloads up to 3,000 kgs.

Technical data		VMS-1000 SD	VMS-3000 SD
Maximum payload	kg	1000	3000
	<i>Rotating axis</i>		
Torque, dynamic	Nm	1878	6315
Rated speed	rpm	0-5.3	0-3.7
Maximum speed	rpm	14.2	10.0

VMS-1000 SD

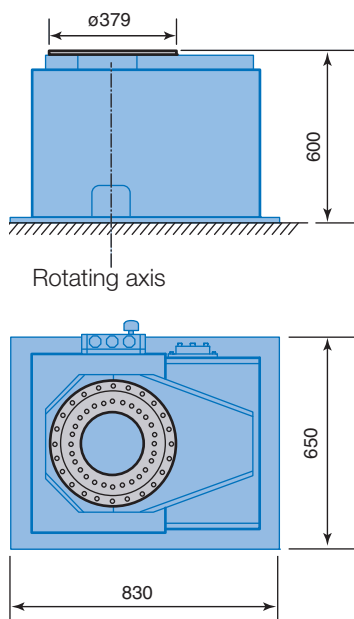

VMS-3000 SD

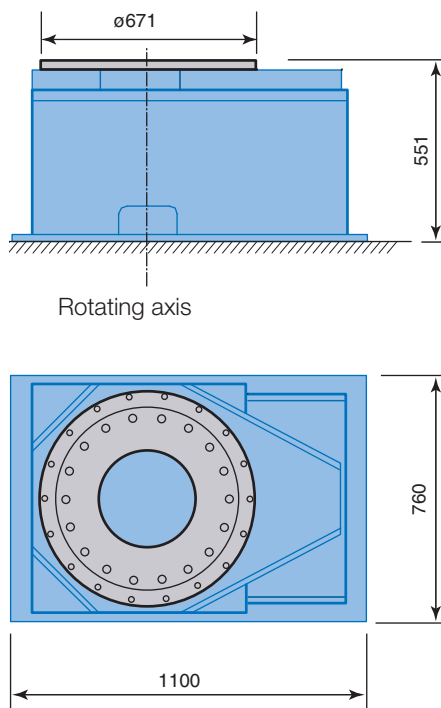

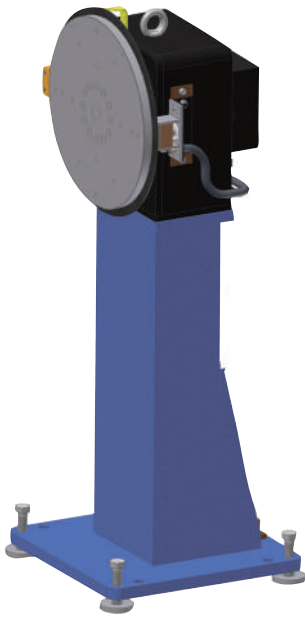

- Stand-alone positioner
- Simple, modular design
- Endless rotation

This is one station positioner for workpieces requiring rotation about one axis. It is a stand alone positioner to be used without tailstock and suitable for integration in e.g. compact welding stations.

Suitable for workpieces with a diameter up to 1300 mm. Maximum payload up to 500 kg.

Available accessories

- Fixture brackets
- Additional current transfer

Technical data		HSC-250 SDM	HSC-500 SDM
Maximum payload	kg	250	500
Welding capacity, 100 % duty cycle	A	350	350
Welding capacity, 60 % duty cycle	A	460	460
Weight	kg	170	175
Height to fixture disc's centre (H)	mm	650, 850, 1000, 1200	650, 850, 1000, 1200
	<i>Rotating axis</i>		
Torque, dynamic	Nm	393	608
Torque, static	Nm	314	486
Rated speed	rpm	0-22.5	0-16.8
Maximum speed	rpm	37	44.3
Axis' rotation		Endless	Endless
Rated offset from COG	mm	128	100
Rated offset from COG, overhang (A)	mm	337	228

HSC-250 SDM, HSC-500 SDM

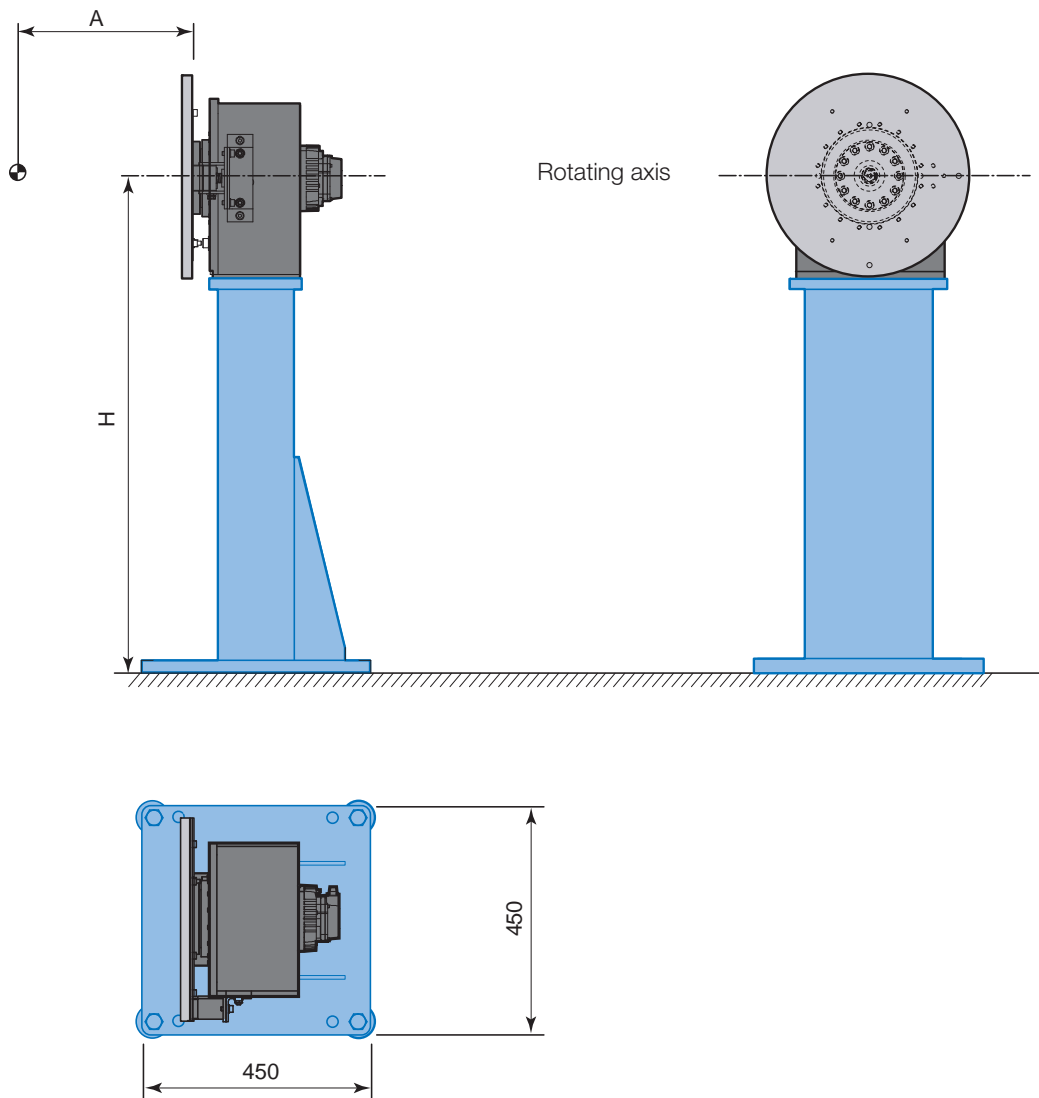

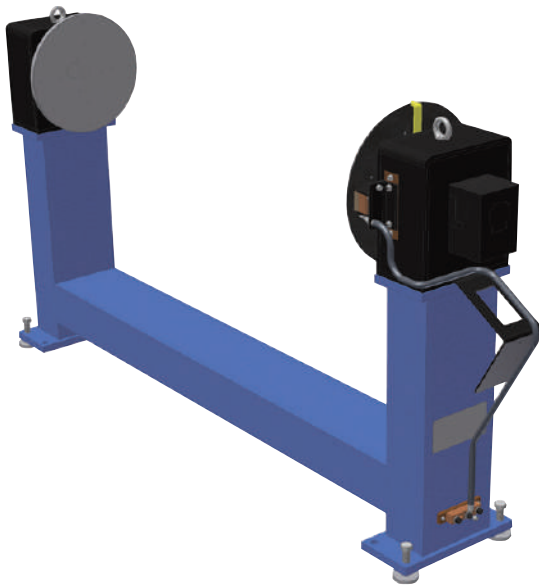

- Several fixture distances available
- Simple, modular design
- Endless rotation

This is one station positioner for workpieces requiring rotation about one axis. It is equipped with a tailstock. The fixture discs on head- and tailstock has endless rotation.

Suitable for workpieces with a diameter up to 1500 mm. Maximum payload up to 500 kg.

Available accessories

- Fixture disc for the tailstock
- Fixture brackets

Options

- Slip ring device
- Controlled air

Technical data		HSD-250 SDM	HSD-500 SDM
Maximum payload	kg	250	500
Welding capacity, 100 % duty cycle	A	350	350
Welding capacity, 60 % duty cycle	A	460	460
Weight	kg	310-350	320-360
Distance between fixture plates (L)	mm	1600, 2000, 2500	1600, 2000, 2500
Maximum fixture's width, diameter (D)	mm	1500	1500
Height to fixture disc's centre (H)	mm	1020	1020
	<i>Rotating axis</i>		
Torque, dynamic	Nm	393	608
Torque, static	Nm	314	486
Rated speed	rpm	0-22.5	0-16.8
Maximum speed	rpm	37	44.3
Axis' rotation		Endless	Endless
Rated offset from COG	mm	128	100

HSD-250 SDM, HSD-500 SDM

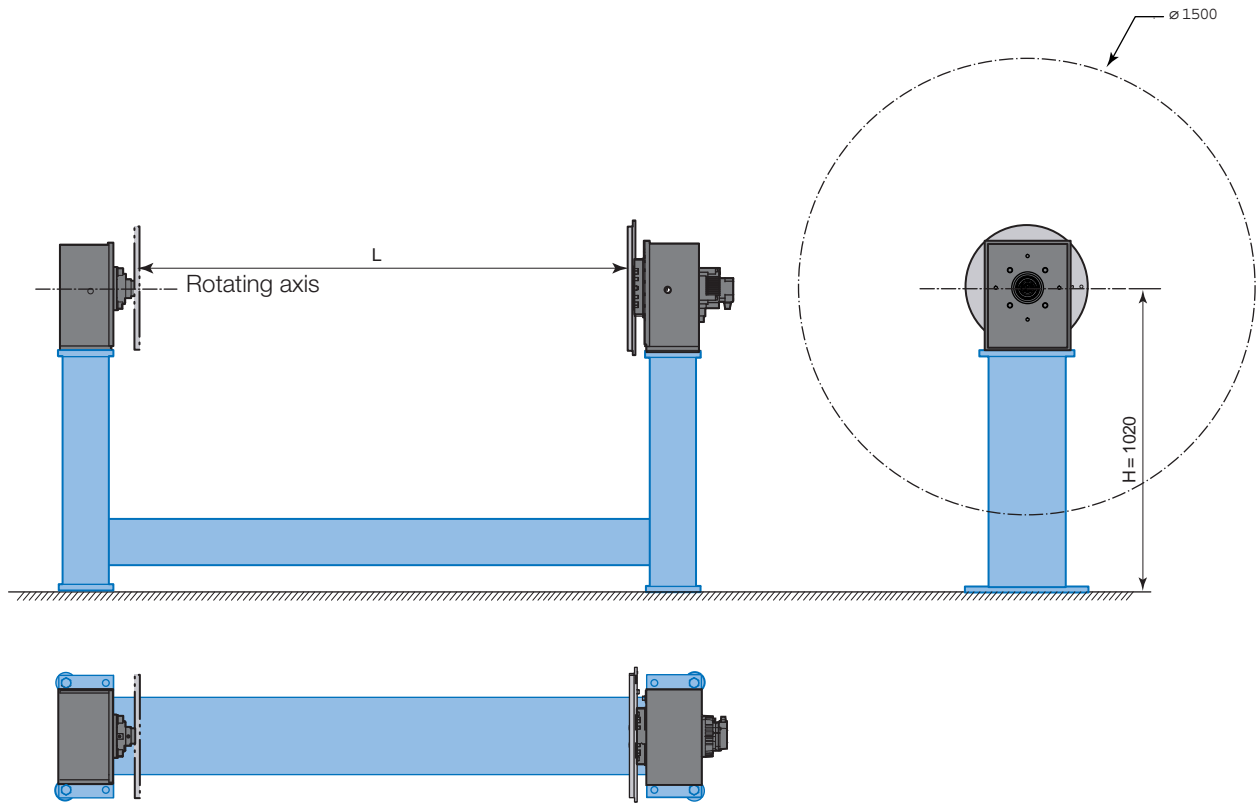

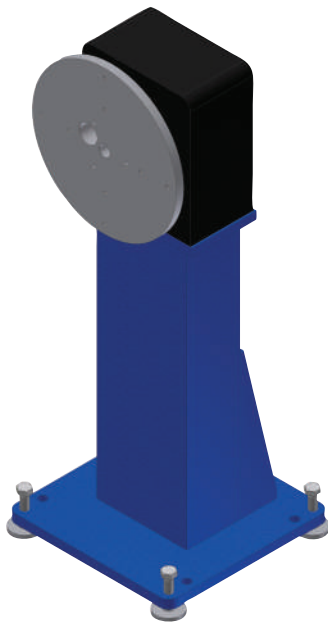

- Stand-alone tailstock
- Simple, modular design
- Prepared for media transfer units

This is a one station tailstock for workpieces requiring rotation about one axis. It is a stand alone tailstock suitable for integration in e.g. compact welding stations.

Suitable for workpieces with a diameter up to 2400 mm.
Maximum payload 1000 kg.

Accessories

- Fixture disc
- Fixture bracket

Options

- Slip ring device
- Controlled air

Technical data		SPE-1000			
Maximum payload	kg	1000			
Maximum fixture width, diameter (D)	mm	1200	1550	1800	2250
Maximum fixture width, diameter (D _{max})	mm	1300	1700	1950	2400
Height to fixture disc's centre (H)	mm	650	850	975	1200
Weight	kg	102	111	117	127

SPE-1000

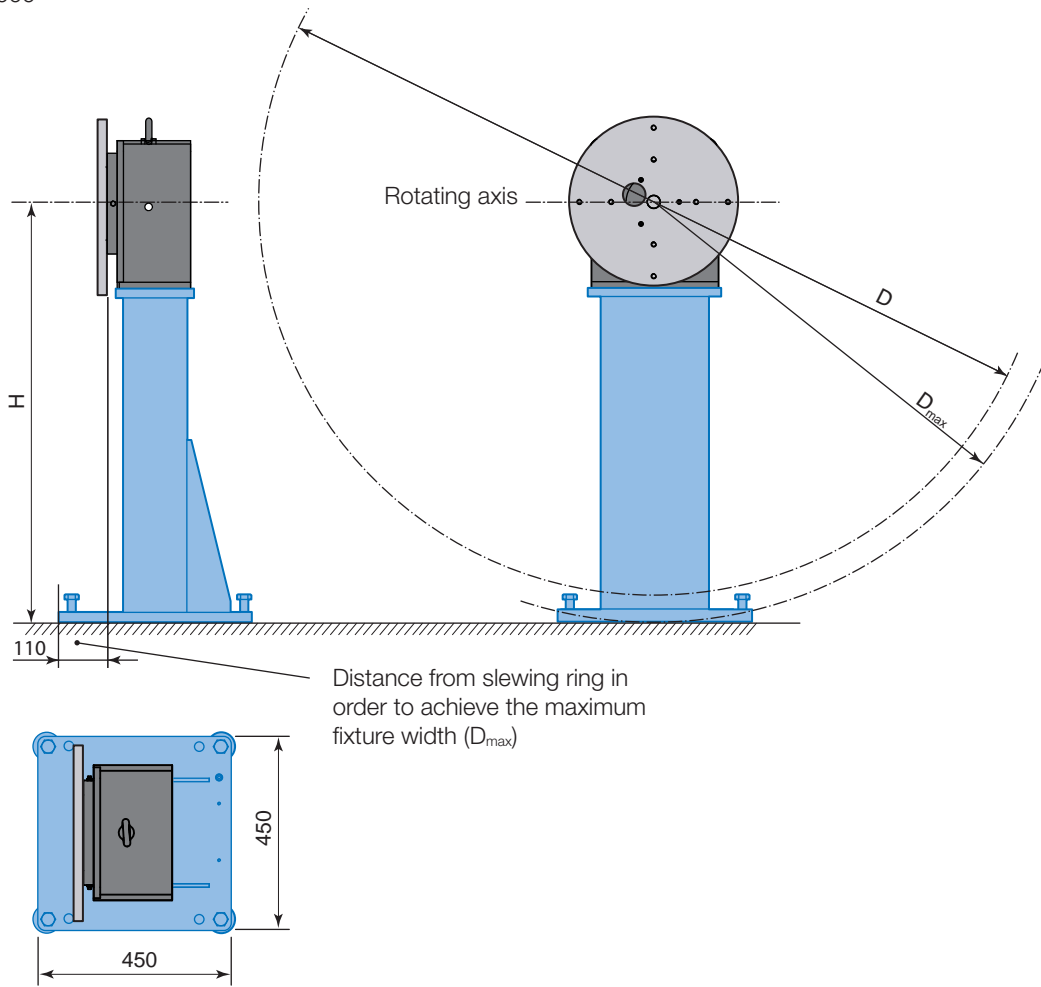

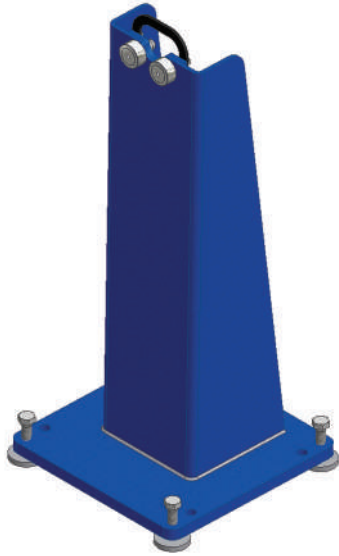

- Stand-alone tailstock
- Simple, modular design
- Light weight fixtures are easily loaded

This is a one station tailstock for workpieces requiring rotation about one axis. It is a stand alone tailstock designed for fixtures with an axis diameter of 50 mm, and suitable for integration in e.g. compact welding stations.

Suitable for workpieces with a diameter up to 1200 mm.
 Maximum payload 500 kg.

Technical data		SPH-500			
Maximum payload	kg	500			
Maximum fixture width, diameter (D)	mm	600	775	900	1125
Maximum fixture width, diameter (D _{max})	mm	650	850	975	1200
Height to fixture disc's centre (H)	mm	650	850	975	1200
Weight	kg	64	72	76	85

SPH-500

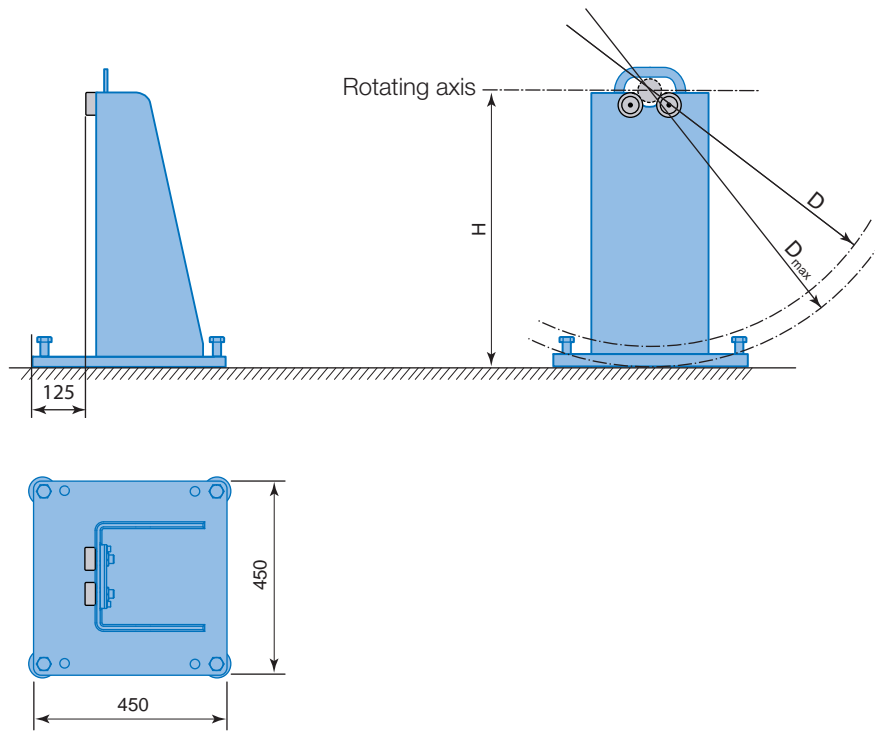

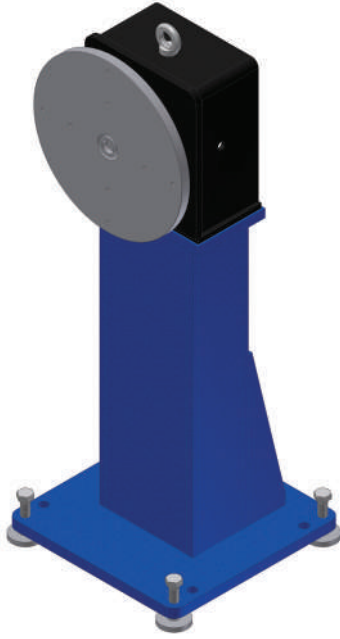

- Stand-alone tailstock
- Simple, modular design

This is a one station tailstock for workpieces requiring rotation about one axis. It is a stand alone tailstock suitable for integration in e.g. compact welding stations.

Suitable for workpieces with a diameter up to 2400 mm.
Maximum payload 1000 kg.

Accessories

- Fixture disc
- Fixture bracket

Technical data		SPF-1000			
Maximum payload	kg	1000			
Maximum fixture width, diameter (D)	mm	1200	1550	1800	2250
Maximum fixture width, diameter (D _{max})	mm	1300	1700	1950	2400
Height to fixture disc's centre (H)	mm	650	850	975	1200
Weight	kg	102	111	117	127

SPF-1000

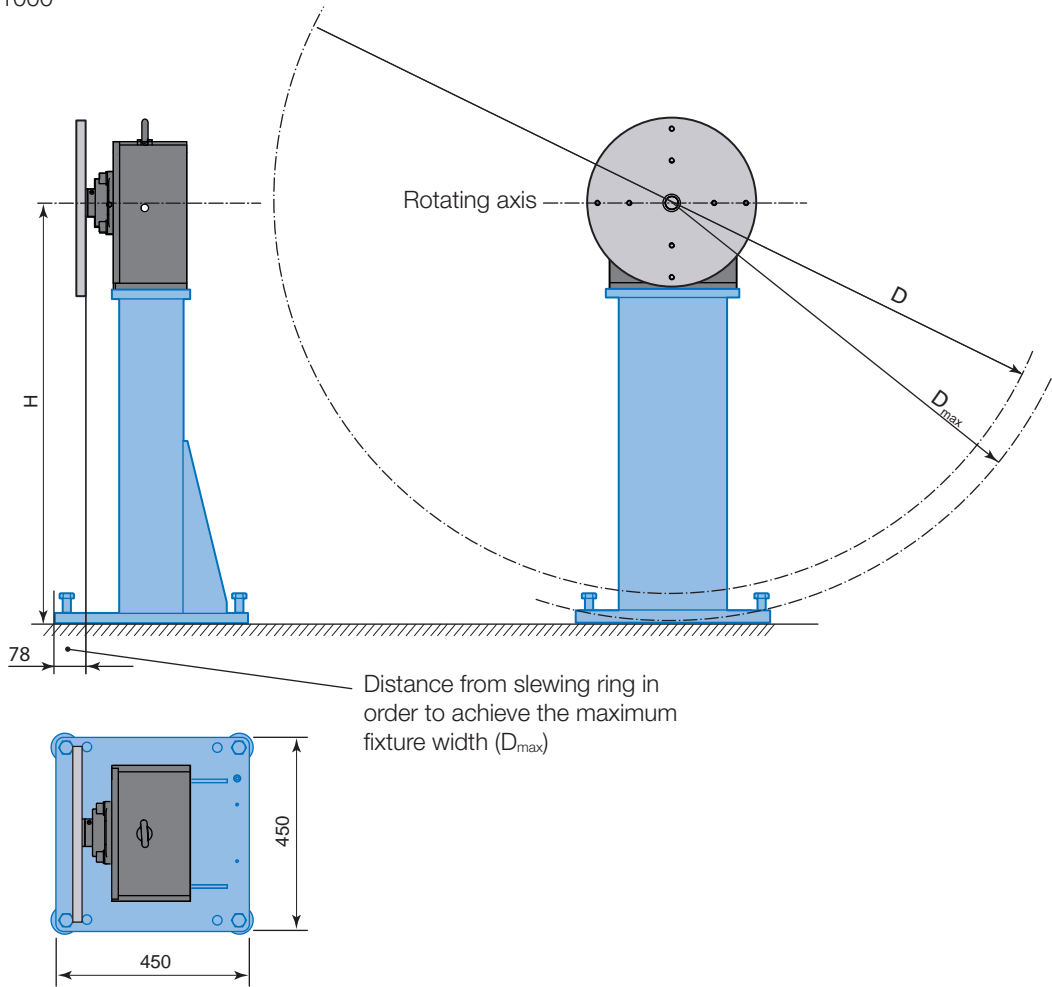

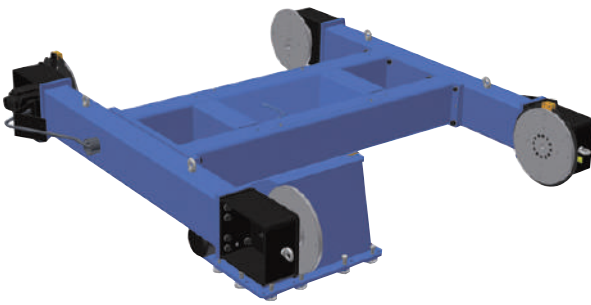

- Simple, modular design
- AC-motor with frequency inverter (index axis)
- Endless rotation

This is a two station positioner for workpieces that require rotation about one axis. It has been designed for operator ease of use, with a suitable working height for loading/unloading the fixtures. The fixture discs on head- and tailstock has endless rotation.

Suitable for workpieces with diameters up to 1300 mm. Maximum payload up to 500 kg on each side.

Available accessories

- Fixture discs for the tailstocks
- Fixture brackets
- Anti-glare shield
- Internal safety cables

Options

- Slip ring device
- Controlled air

Technical data		VMH-250 S2DM	VMH-500 S2DM
Maximum payload, per station	kg	250	500
Welding capacity, 100 % duty cycle	A	350	350
Welding capacity, 60 % duty cycle	A	460	460
Weight	kg	1300-1350	1370-1420
Distance between fixture plates (L)	mm	1600, 2000	1600, 2000
Maximum fixture's width, diameter (D)	mm	1300	1300
Height to fixture disc's centre (H)	mm	845	845
<i>Index axis</i>			
Torque, static	Nm	1574	2018
Index time	sec	7	7
Rated speed	rpm	0-9.1	0-7.1
<i>Rotating axis</i>			
Torque, dynamic	Nm	393	608
Torque, static	Nm	314	486
Rated speed	rpm	0-22.5	0-16.8
Maximum speed	rpm	37	44.3
Axis' rotation		Endless	Endless
Rated offset from COG	mm	128	100

VMH-250 S2DM, VMH-500 S2DM

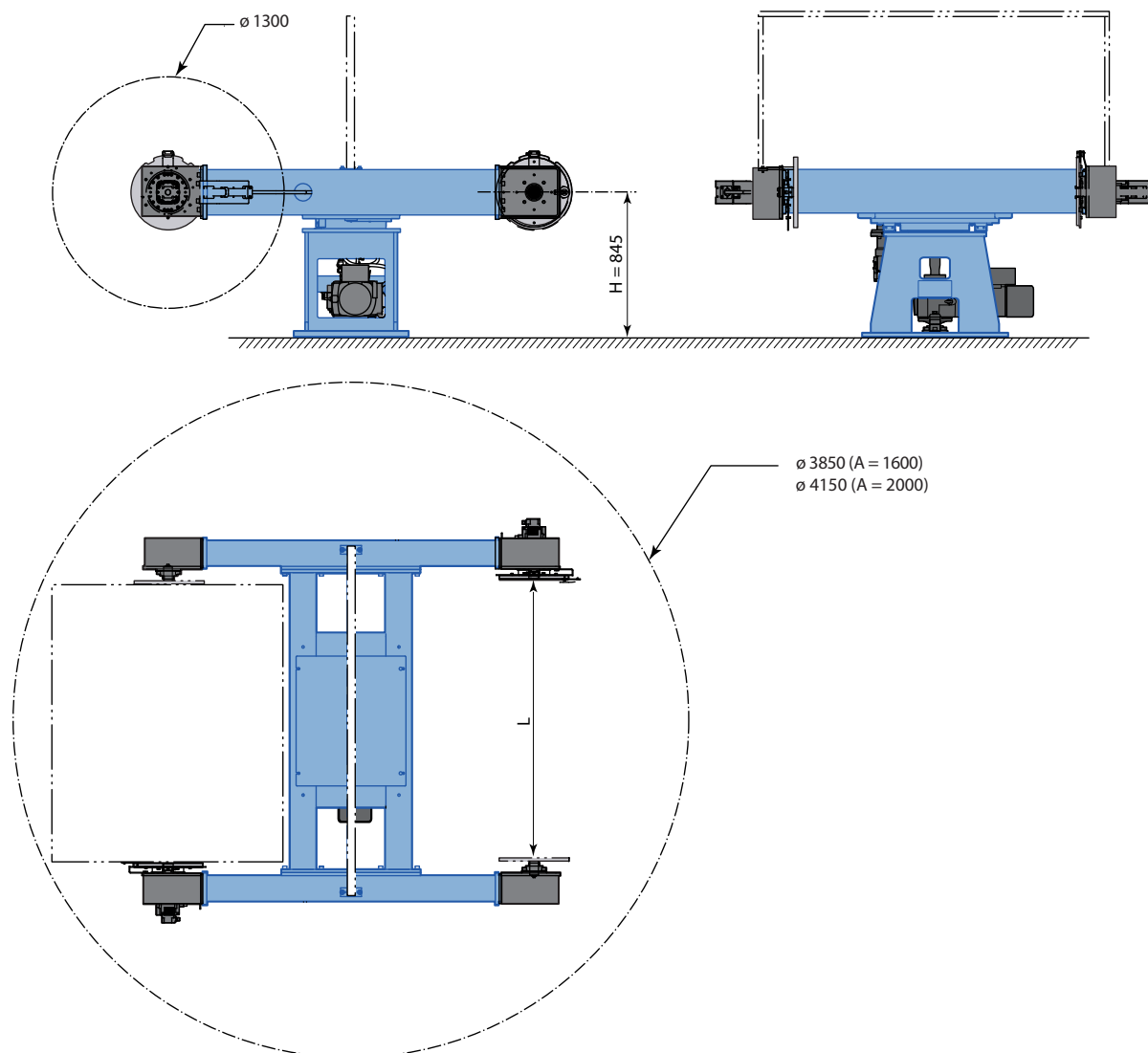

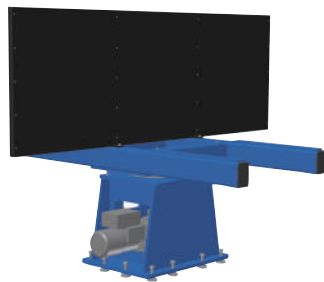
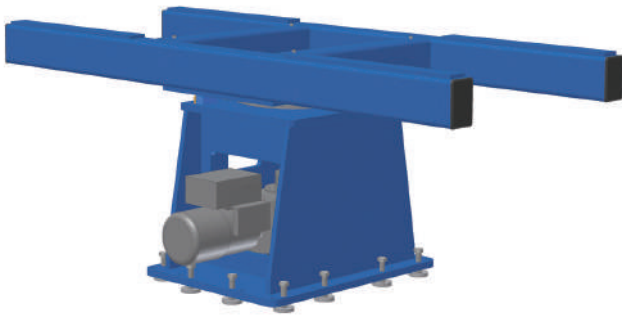

- Simple, modular design
- AC-motor with frequency inverter
- Compact design

This is a two station turntable for workpieces in a fixed position during welding. It has been designed for operator ease of use, with a suitable working height for loading/unloading the fixtures.

Maximum payload up to 500 kg on each side.

Available accessories

- Anti-glare shield

Technical data		VMI-500 NM
Maximum payload, per station	kg	500
Welding capacity, 100 % duty cycle	A	350 A
Welding capacity, 60 % duty cycle	A	460 A
Weight	kg	770
Maximum fixture size	mm	700 x 1200
Height to fixture surface (H)	mm	882
<i>Index axis</i>		
Torque, static	Nm	1574
Index time	sec	7
Rated speed	rpm	0-9.1

VMI-500 NM

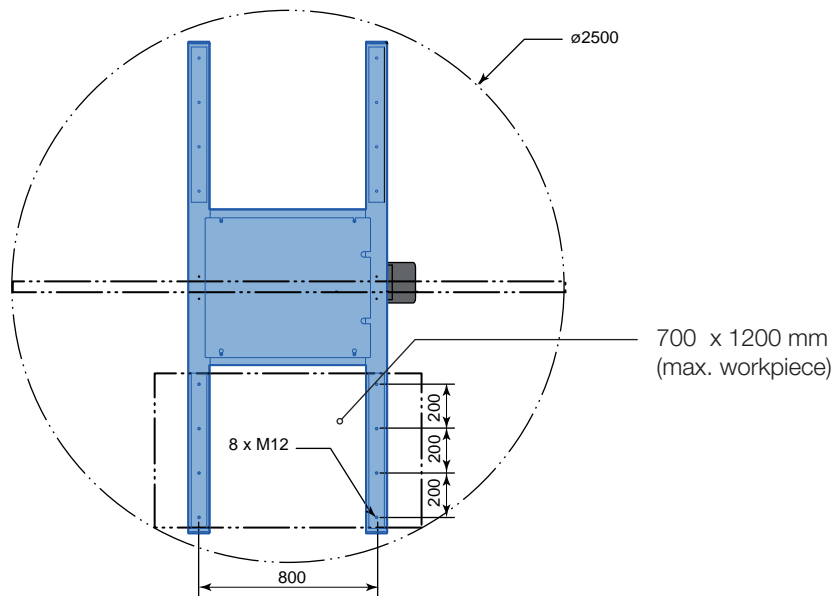
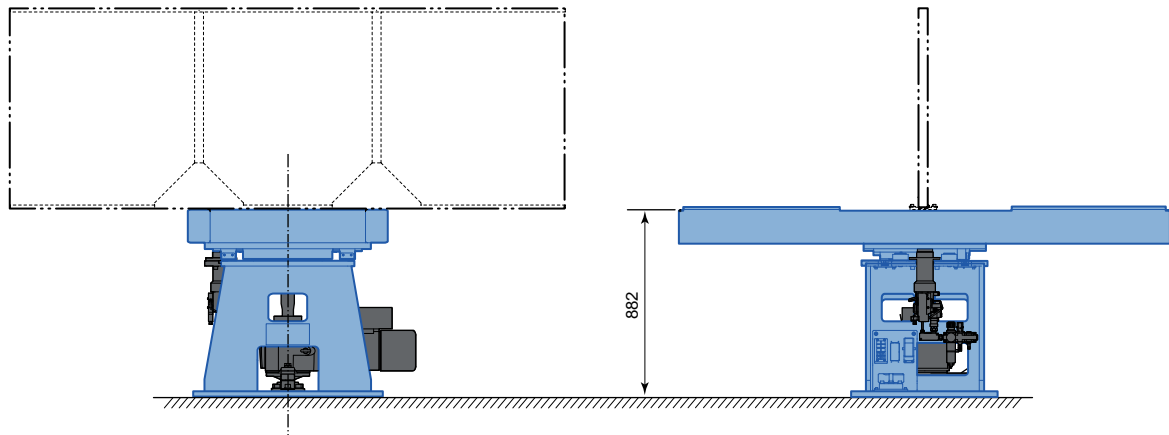

VST

Rotating robot base & Tracks

Rotating robot base



VST-600
Direct drive

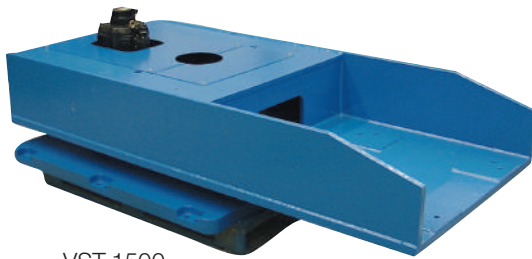

VST-1500
Slewing drive

- Increasing the robot's working area
- High speed – short cycle time
- Direct or slewing drive

This is a servo powered rotating base for extending the robot's working radius e.g. when using the robot for machine tending or press brake application.

Three sizes covers the whole MOTOMAN robot range with handling capacity from 6 to 500 kgs.

Options

- Limiting rotation $\pm 90^\circ$ or $\pm 120^\circ$ (VST-600)

Technical data		VST-600 SD	VST-1500 SD	VST-2500 SD
Maximum payload	kg	600	1500	2500
Increased robot reach (A)	mm	1000 ¹⁾ , 1100 ²⁾	1000 ³⁾	1000 ⁴⁾
Torque, dynamic	Nm	2299	6675	9717
Maximum rotation		$\pm 142^\circ$	$\pm 135^\circ$	$\pm 135^\circ$
Rated speed	rpm	0-12.6	0-4.4	0-3.1
Maximum speed	rpm	16.8	10.3	7.2

¹⁾ MH50, MH50-20, MH50-35

²⁾ MH6, MH6S, VA1400, MA1400, MA1800, MA1900

³⁾ ES165D, ES200D

⁴⁾ UP350D, UP350D-500, UP350D-600

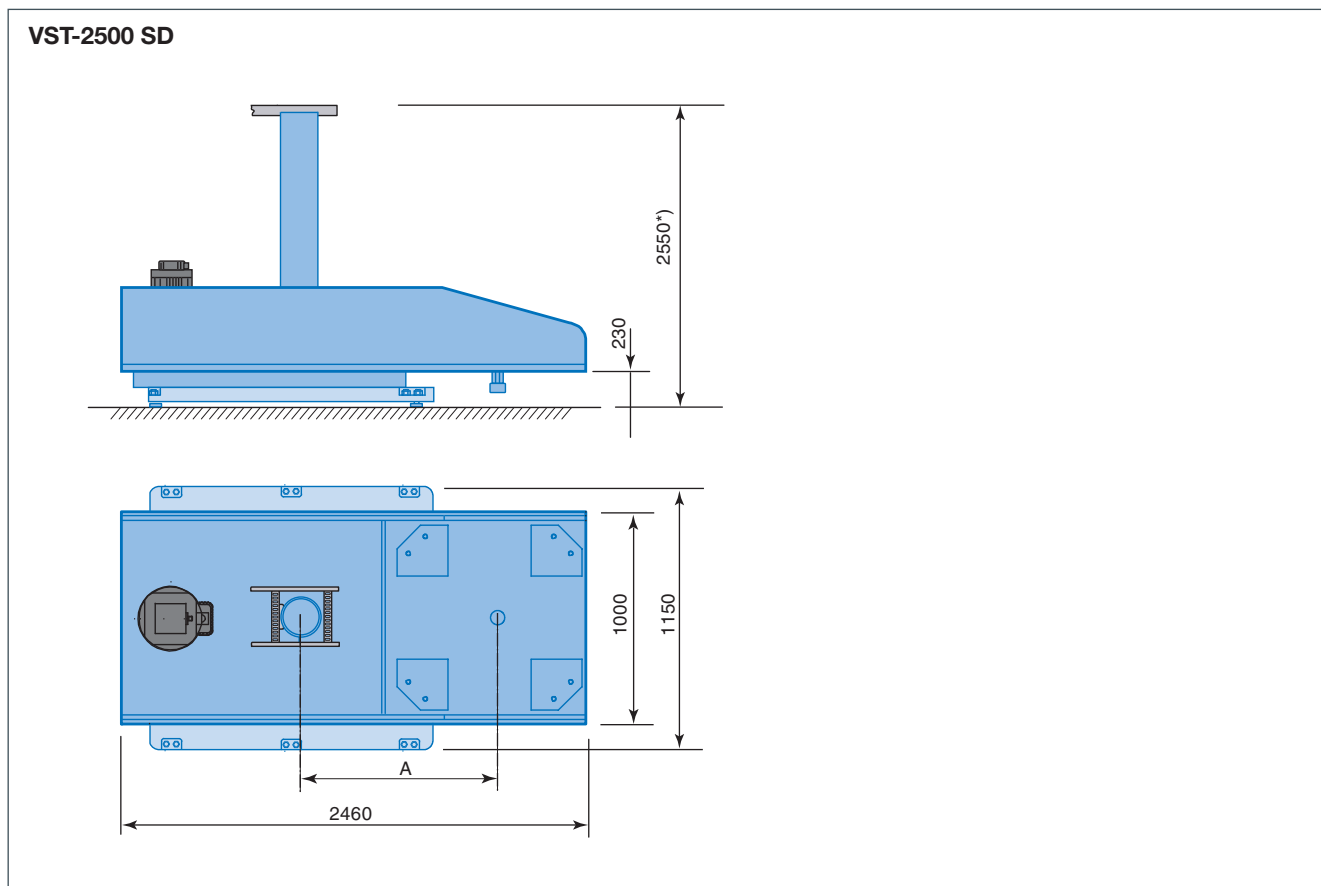
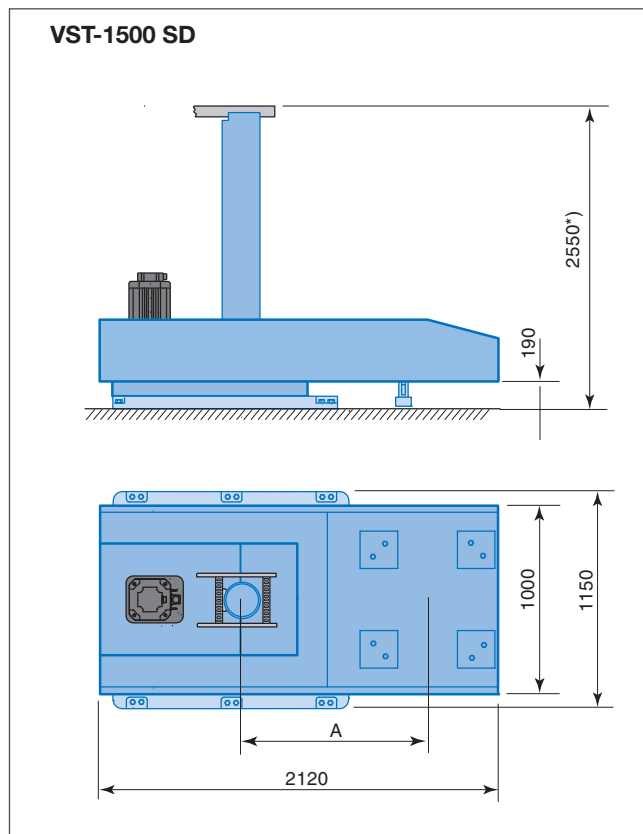
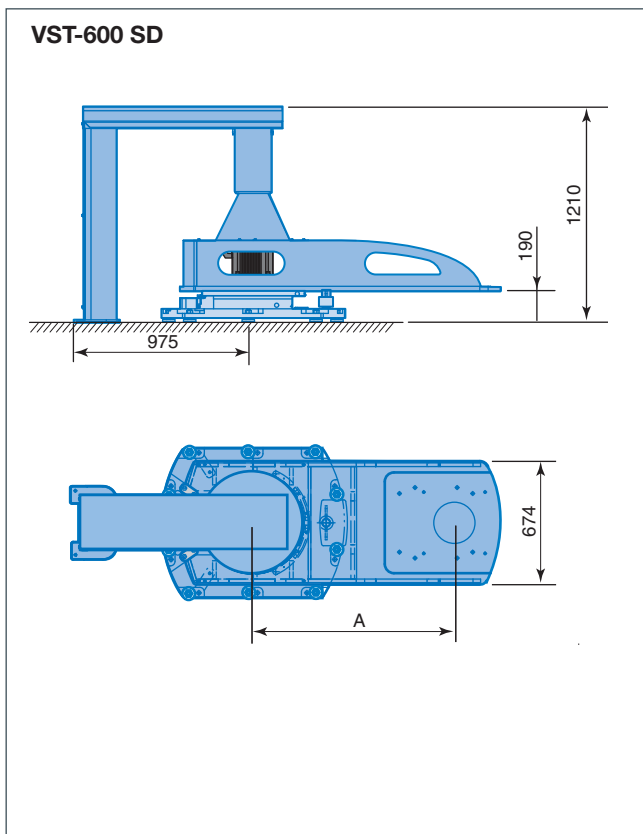

TSL

Rotating robot base & Tracks
Floor mounted track



- Outstanding speed
- Quiet operation
- Dedicated arc welding track

This is a servo powered floor mounted track with one robot carrier. It can be used to increase the robot's working range e.g. when welding large objects. The TSL track is prepared for zeroing function.

The TSL-600 track is only available in two, three or four meters total length.

Options

- Automatic lubrication (rack and guide blocks)
- Robot stands in different heights
- Bracket for wire barrel

Technical data		TSL-600 SD				
Maximum payload	kg	600				
Maximum speed	m/s	1.8				
ED	%	50				
Acceleration velocity	m/s ²	3.0				
Travel 500 mm	sec	0.83				
Travel 1000 mm	sec	1.16				
Repetitive position accuracy	mm	±0.05				
Height (H) including robot stand	mm	687	887	1087	1287	1487
Standard length (L)	meter	2,3 or 4				
Travel length (stroke)	mm	L-850				
Suitable for industrial robots		MH6, MH6-10, MH6S, HP20D, MA1400, MA1900				

TSL-600 SD

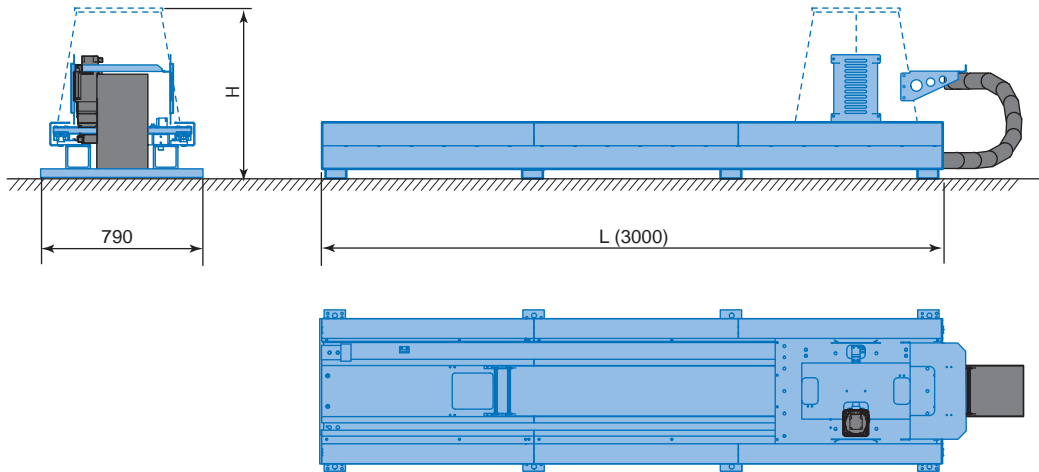

TSL

Rotating robot base & Tracks
Floor mounted track

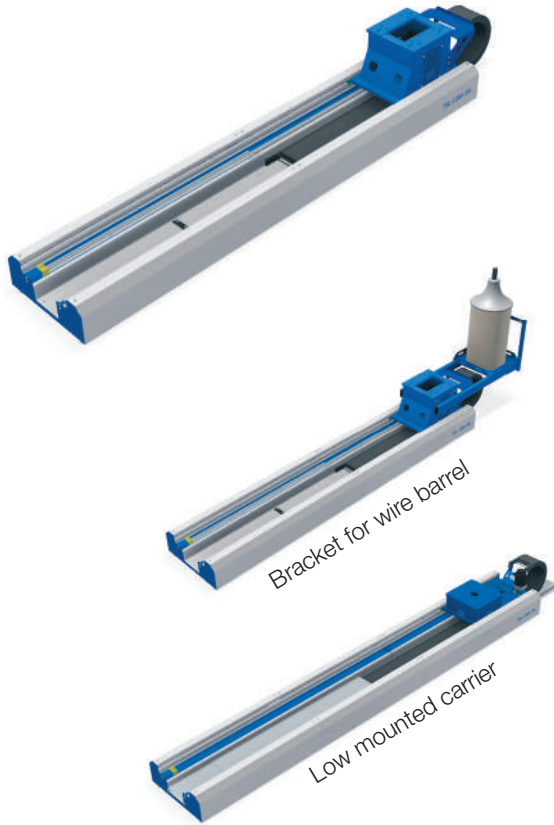

- Outstanding speed
- Quiet operation
- Cost efficient

This is a servo powered floor mounted track with one or two robot carriers. It can be used to transport a robot from one station to another, or to increase the robot's working range e.g. when welding large objects. The TSL track is prepared for zeroing function.

Since the track is built in two- or four meter modules, it is easy to extend to a suitable length.

Options

- Automatic lubrication (rack and guide blocks)
- Zone limitations (up to four zones)
- Additional carrier
- Brackets for wire barrel

Technical data		TSL-1000 SD					
Maximum payload, per wagon	kg	1000					
ED	%	50					
Maximum speed	m/s	1.8					
Acceleration velocity	m/s ²	2.25 ¹⁾					
Travel 500 mm	sec	0.94 ²⁾					
Travel 1000 mm	sec	1.34 ³⁾					
Repetitive position accuracy	mm	±0.05					
Height (H) including robot stand	mm	687	887	1087	1287	1487 ⁴⁾	Low mounted 467
Standard length (L) in 2 meter steps	meter	2-24	2-24	2-24	2-24	2-24	2-24
Travel	mm	L-850	L-850	L-850	L-850	L-850	L-1050
Suitable for industrial robots		MH6, MH6-10, MH6S, MP20D, MH50-20, MH50-35, MA1400, MA1900, MA1800					

¹⁾ for maximum payload up to 600 kg = 3.0

²⁾ for maximum payload up to 600 kg = 0.83

³⁾ for maximum payload up to 600 kg = 1.16

⁴⁾ suitable for robot models MH6-10, MH6S, MH6, HP20D, MA1400 and MA1900 only

TSL-1000 SD

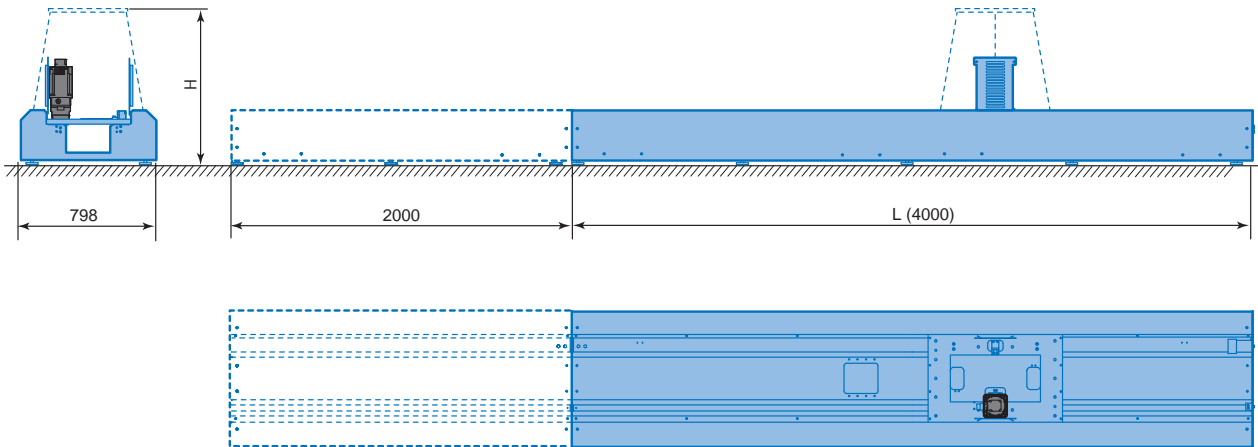

TSL

Rotating robot base & Tracks
Floor mounted track

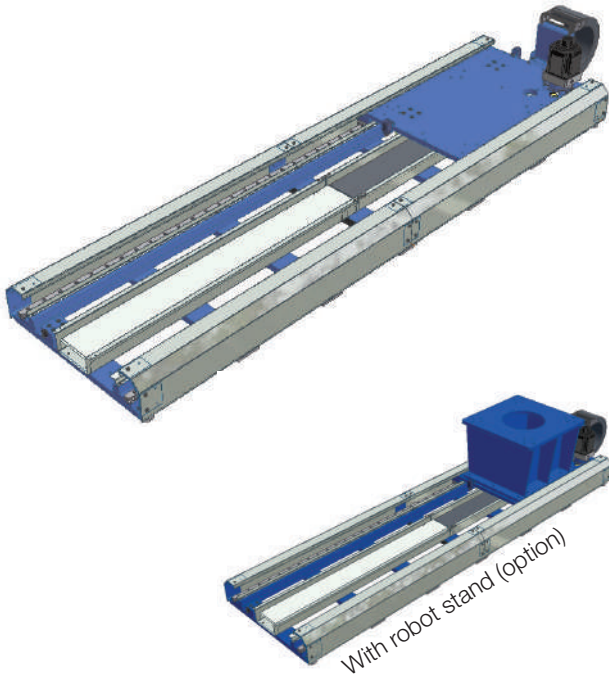

- Outstanding speed
- Quiet operation
- For high payload robots

This is a servo powered floor mounted track with one or two robot carriers. It can be used to transport a robot from one station to another, or to increase the robot's working range. The TSL track is prepared for zeroing function.

Since the track is built in two- or four meter modules, it is easy to extend to a suitable length.

Options

- Automatic lubrication (rack and guide blocks)
- Integrated robot stands, height 440, 800 and 1200 mm ²⁾
- Additional carrier
- Zone limitations (two, three or four zones possible)
- Mechanical zeroing function

Technical data		TSL-2000 SD	TSL-4000 SD
Maximum payload	kg	2000	4000
Maximum speed	m/s	1.8	1.6
ED	%	50	50
Acceleration velocity	m/s ²	2.25	2.0
Travel 1200 mm	sec	1.45	1.55
Repetitive position accuracy	mm	±0.08	±0.08
Height (h)	mm	236	236
Height (H) including robot stand	mm	636, 836	636, 836
Standard length (L) in 2 meter steps	meter	4-24	4-24
Travel length (stroke)	mm	L-1340	L-1340
Suitable for industrial robots		ES165D-100, ES165D ES200D	ES165D-100, ES165D ES200D, ES280D MPL160, MPL300, MPL500 UP350D, UP350D-500 ¹⁾

¹⁾ UP350D and UP350D-500 must be mounted on an integrated robot stand

²⁾ With robot stand 1200 mm it may be necessary to reduce the travel speed

TSL-2000 SD, TSL-4000 SD

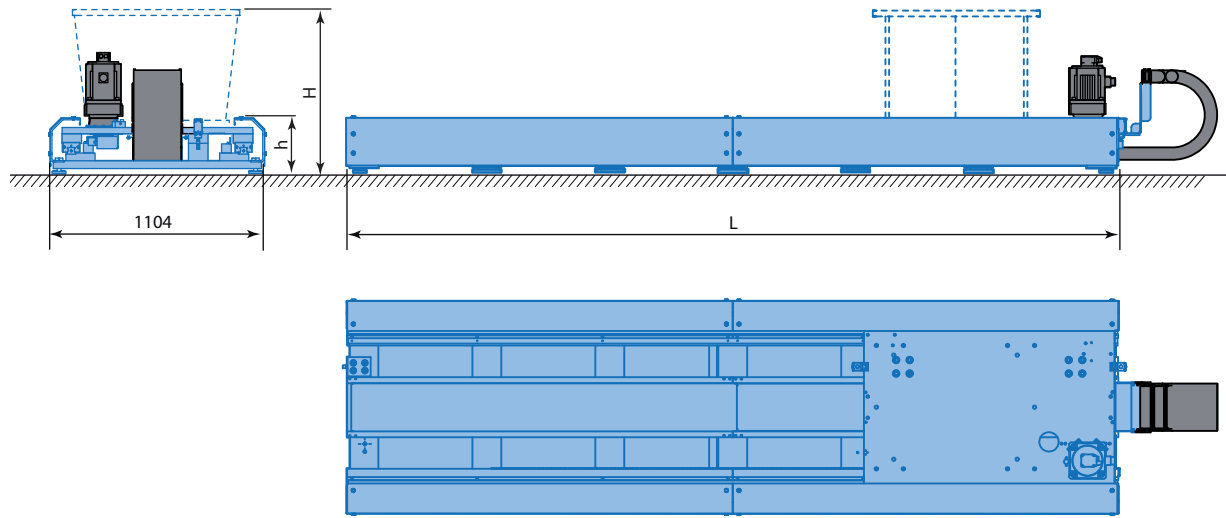



- Outstanding speed
- Single or twin robots
- Cost efficient

This is a gantry designed for reliable, accurate and economic welding solutions for large components such as excavators, containers and earth moving equipment etc. The TSG is servo powered and fully synchronized with the robot controller.

The TSG is built up by two and four meter modules to any desired length with a suitable number of supporting pillars. In the twin systems, with several robots applied to the Y-beam, the robots can work together or independent of each other.

Options

- Pillar height (H): 4300, 4600 or 4900 mm
- Additional carrier
- Zone limitations (up to four zones)
- Bracket mount for TSG-y
- Accompanying wire barrel

Technical data			TSG-y	TSG-yx	TSG-yz	TSG-yxz
		<i>y-axis</i>				
Travel length		mm	L-975	L-1100	L-1100	L-1100
Standard length (L) in 2 meter steps		meter	4-24	4-24	4-24	4-24
Standard pillar height		meter	4	4	4	4
Maximum speed, 50% duty cycle		m/s	1.5	1.5	1.5	1.5
Acceleration		m/s ²	1.5	1.5	1.5	1.5
Travel	0.5 / 1.0 meter	s	1.24 / 1.72	1.24 / 1.72	1.24 / 1.72	1.24 / 1.72
Travel	1.2 / 1.5 meter	s	1.87 / 2.08	1.87 / 2.08	1.87 / 2.08	1.87 / 2.08
		<i>x-axis</i>				
Travel length		mm	--	2000	--	2000
Maximum speed, 50 % duty cycle		m/s	--	1.5	--	1.5
Acceleration		m/s ²	--	2.5	--	2.5
Travel	0.5 / 1.0 meter	s	--	0.98 / 1.35	--	0.98 / 1.35
Travel	1.2 / 1.5 meter	s	--	1.49 / 1.69	--	1.49 / 1.69
		<i>z-axis</i>				
Travel length		mm	--	--	1500	1500
Maximum speed, 20% duty cycle		m/s	--	--	0.5	0.5
Acceleration		m/s ²	--	--	1.25	1.25
Travel	0.5 / 1.0 meter	s	--	--	1.33 / 2.31	1.33 / 2.31
Travel	1.2 / 1.5 meter	s	--	--	2.70 / 3.29	2.70 / 3.29
Suitable for industrial robots			1)	2)	3)	3)

¹⁾ MH6, MH6-10, HP20D, MA1400, MA1900, MA1800, MH50-20, MH50

²⁾ MH6, MH6-10, HP20D, MA1400, MA1900, MA1800

³⁾ MH6, MH6-10, HP20D, MA1400, MA1900

TSG-yxz

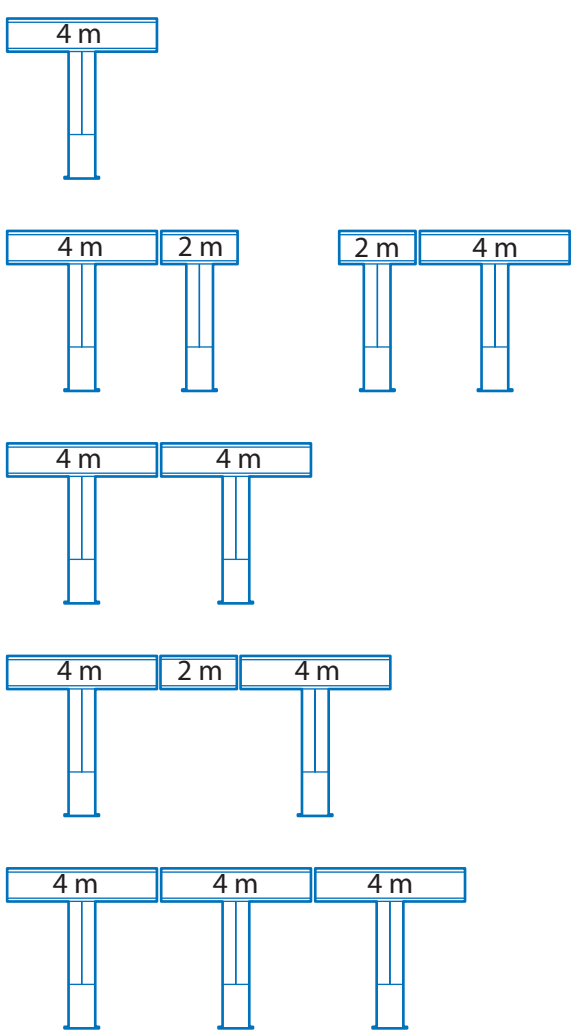
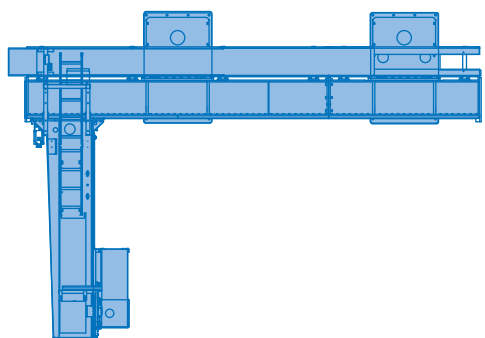
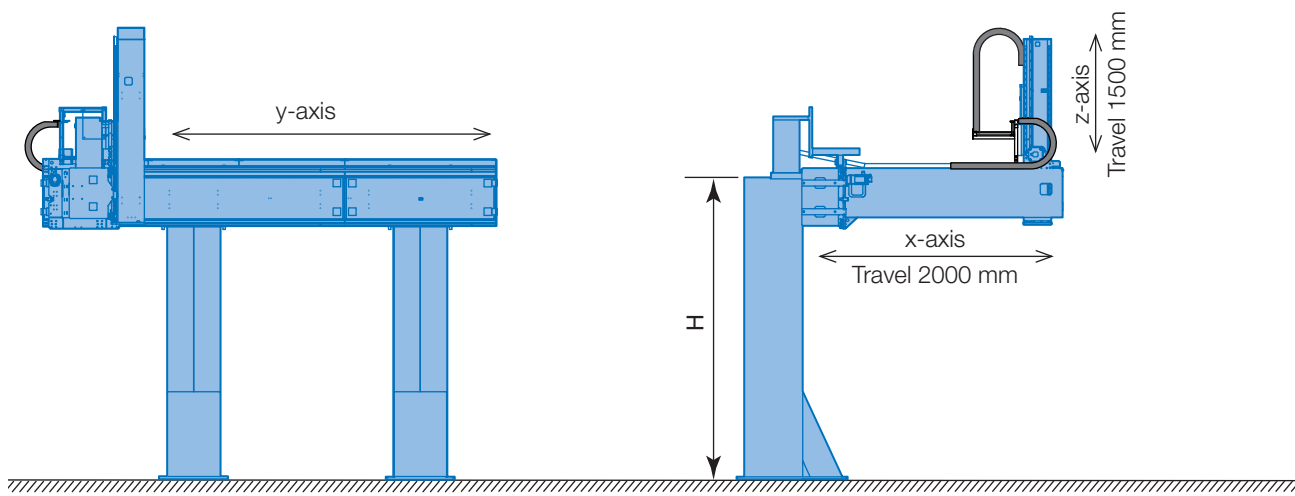

Possible mounting positions

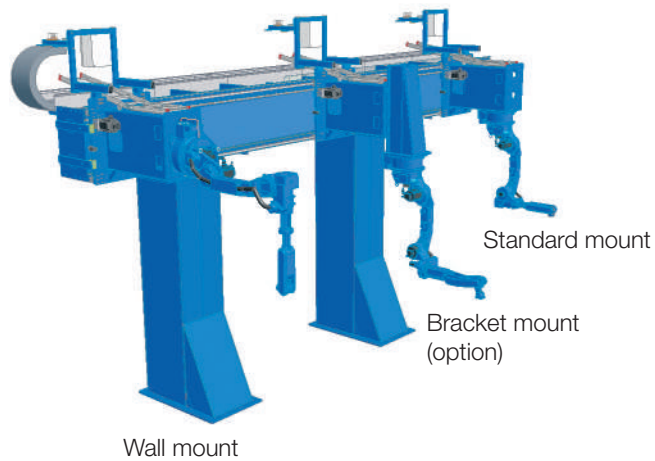

Additional carriage

Additional carriage with built-in (mechanical and electrical) protection against collision with the other carriage.

- Y-carriageKN71.1
- YX-carriageKN73.1
- YZ-carriageKN75.1
- XYZ-carriageKN77.1

TSG-Y

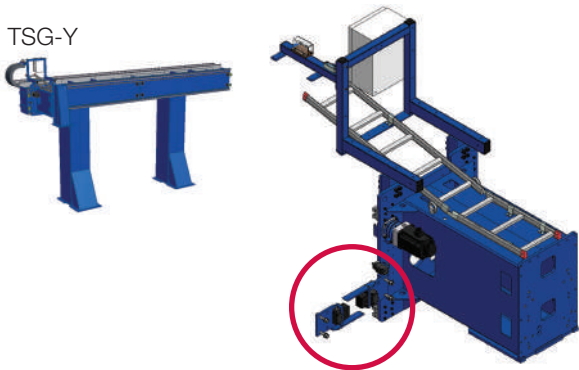

TSG-YZ

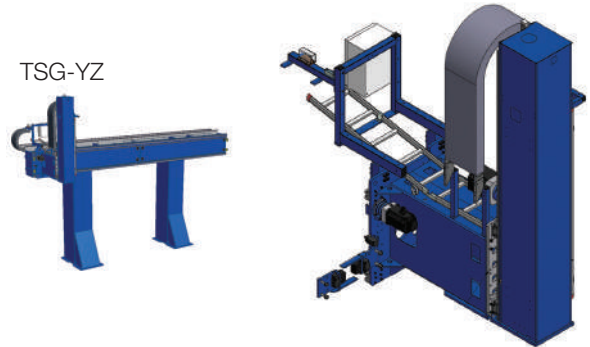

TSG-YX

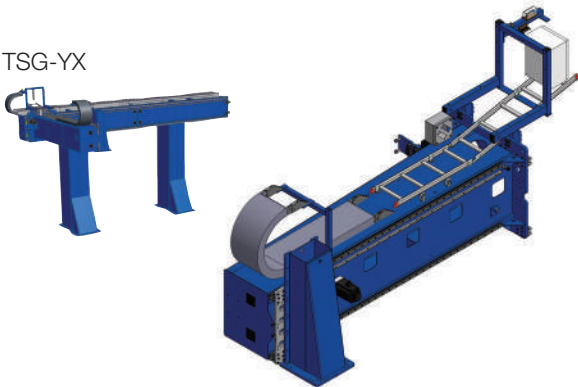

TSG-YXZ

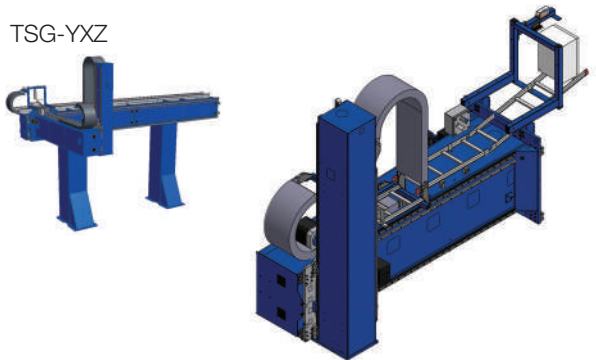

Accompanying wire barrel

Prevent wire feeding troubles with an accompanying wire barrel that will follow the robot.

- Accompanying wire barrelKN87

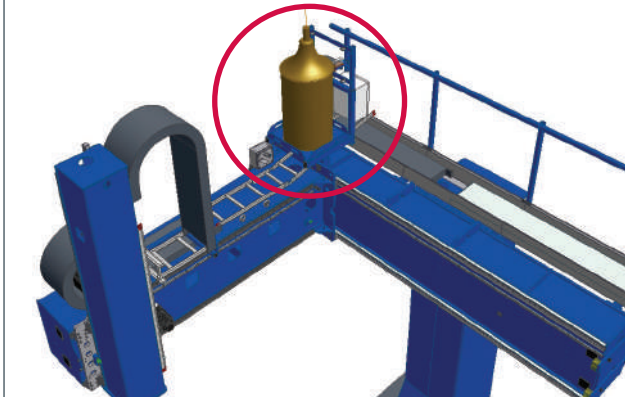

Robot bracket

The robot bracket makes it possible to adjust the robot's position (height and distance from the beam) prior to installation.

- Robot bracketKN83

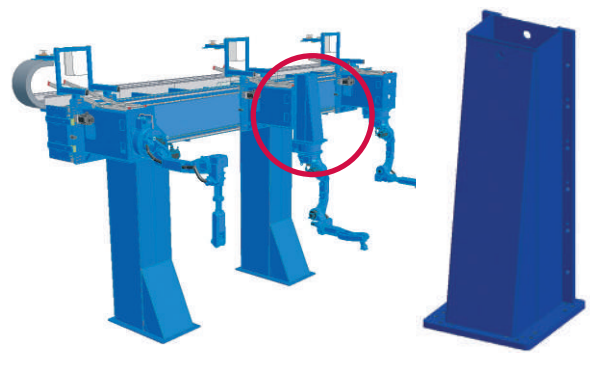

Zone monitoring

When the robot is working in one station, you can make sure human operators are safe in other parts of the cell. The safety sensor will break the circuit if the robot is moving out of its designated zone.

- Two zones KN80.1
- Three zones . . . KN80.2
- Four zones . . . KN80.3

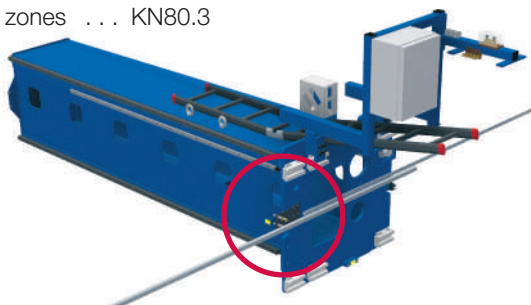

Service platform

A practical platform for service and programming. Depending on where you put the railing, the platform can be mounted on either end (left or right) of the gantry's Y-beam. Size 1010x1240 mm.

Service platformKN81

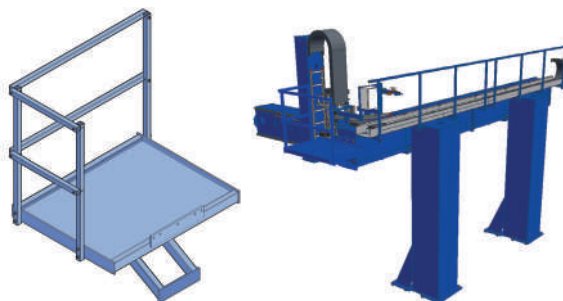

Ladder to service platform

With a safety railing on top to prevent accidental falls. Delivered in a length that corresponds to the height of the gantry.

Ladder to service platformKN92



Pillar height (mm)

- H = 4300 KN94
- H = 4600 KN95
- H = 4900 KN96

Automatic lubrication for the rails

Facilitate maintenance with an automatic lubrication unit that can be programmed to dispense grease at suitable intervals. Replace the whole grease cartridge when empty.

- Y-railsKN88
- YX-railsKN89
- YZ-railsKN90
- YXZ-railsKN91
- Grease cartridge (500 ml) . 6045258

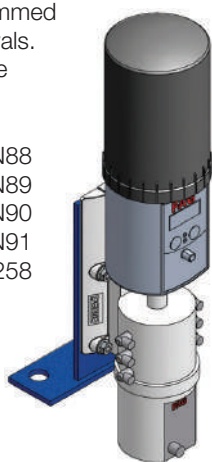

Automatic lubrication for the rack

Facilitate maintenance with an automatic lubrication unit that can be set to dispense grease at suitable intervals.

- Y-pinionKN84
- X-pinionKN85
- Z-pinionKN86

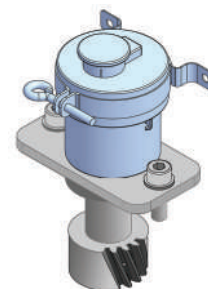

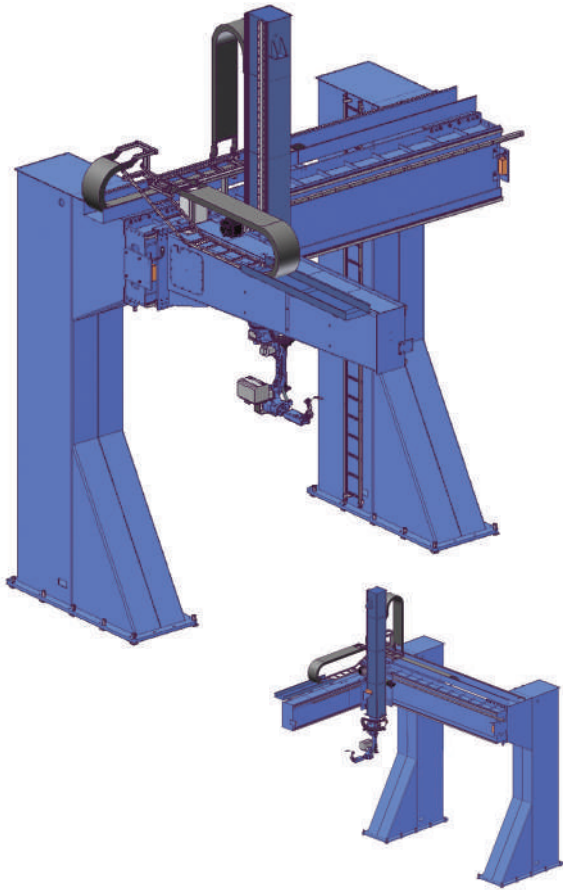

- Travel in three directions
- Single, twin or triple robots
- Outstanding robot working area

The HD-Gantry has been designed to provide a reliable, accurate and economic welding solution for production of large components such as excavators, containers and earth moving equipment etc. The HD-Gantry is servo powered and fully synchronized with the robot controller.

The gantry's x-beam is built up by 3-meter modules to any desired length with a suitable number of supporting pillars.

In the twin or triple systems, with several robots applied to the x-beam, the robots can work together or independent of each other.

Technical data		HD-xyz
	<i>x-axis</i>	
Travel length	mm	6,000-24,000
Maximum speed	m/sec	0.5
Rated speed	m/sec	0.36
	<i>y-axis</i>	
Travel length	mm	2560, 3100
Maximum speed	m/sec	0.5
Rated speed	m/sec	0.36
	<i>z-axis</i>	
Travel length	mm	2000, 2500
Maximum speed	m/sec	0.27
Rated speed	m/sec	0.17
Suitable for robots		MH6, MH6S, MH6-10, HP20D, HP20D-6, MA1400, MA1900

HD

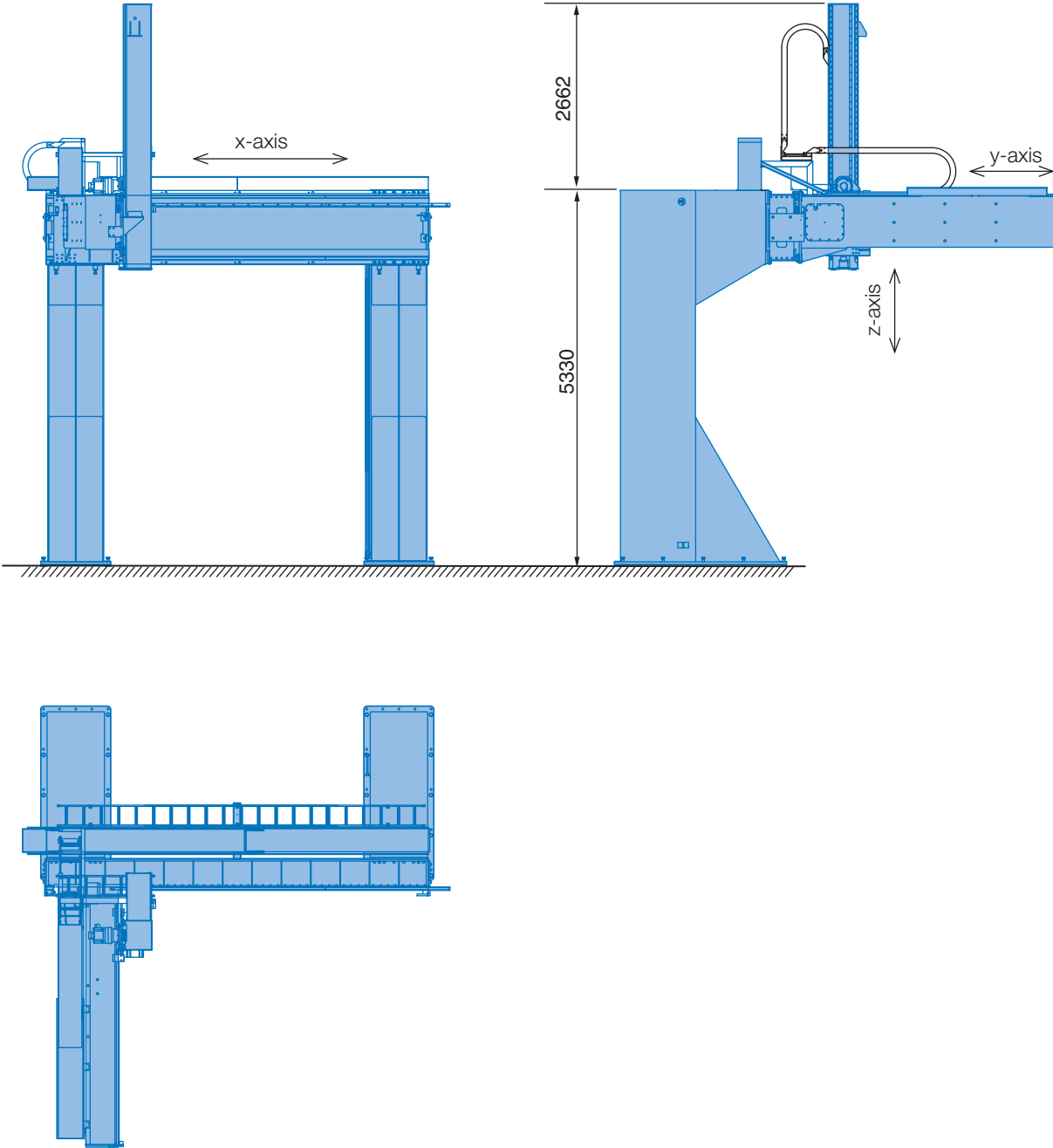

Positioner options

Controlled air and signal transfer



Air connection:

- ◆ 2x direct air 8 mm
- ◆ 2x controlled air 8 mm



Air connection:

- ◆ 2x direct air 8 mm

Signal transfer:

- ◆ 12 channels [BUS] - Profibus, Devicenet, ASi
- ◆ 12 or 24 active channels



Air connection:

- ◆ 1x direct air 3/8"

Signal transfer:

- ◆ 12 channels [BUS] - Profibus, Devicenet, ASi
- ◆ 12 or 24 active channels



RM2, VMF

1x direct air 1/4"
by default.

Air connection:

- ◆ additional 1x direct air 1/4"
- ◆ 2x controlled air 1/4"

Signal transfer:

- ◆ 12 channels [BUS] - Profibus, Devicenet, ASi
- ◆ 12 or 24 active channels

Robot and positioner

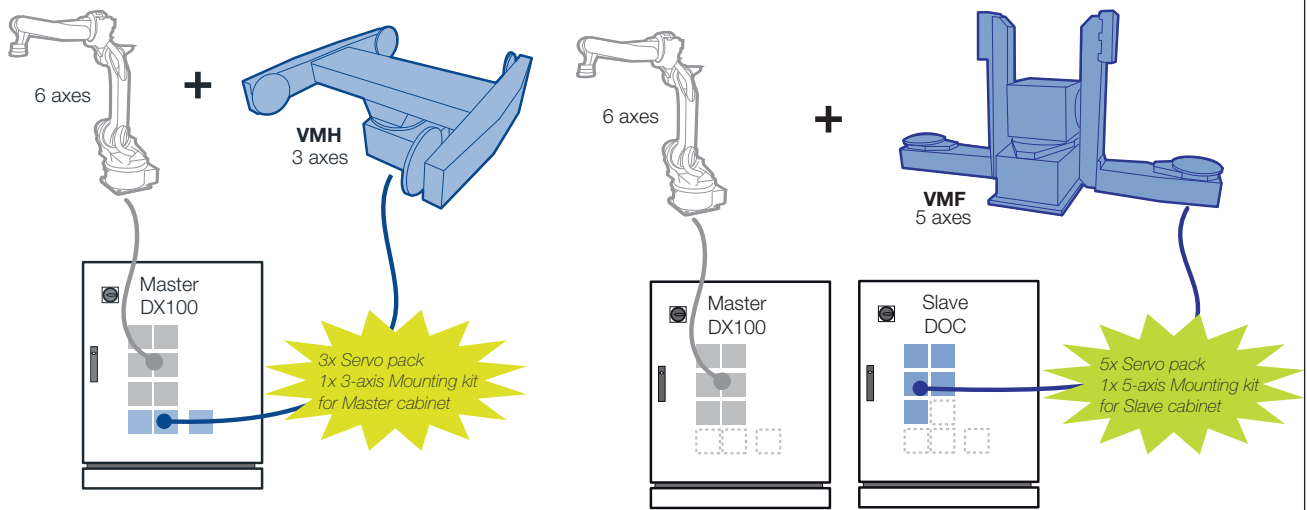

Robot, positioner and track

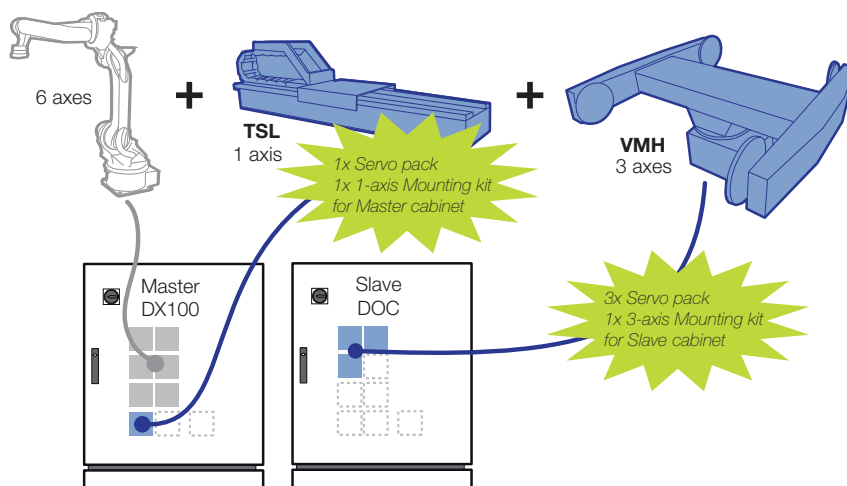



© YASKAWA Nordic AB · 2014-06

 **YASKAWA**

YASKAWA Nordic AB
PO Box 504, SE-385 25 Torsås
SWEDEN

Phone +46 (0)480 417 800
www.motoman.se

