



Robots

KUKA Robot Group

## KR 5 arc

### Specification

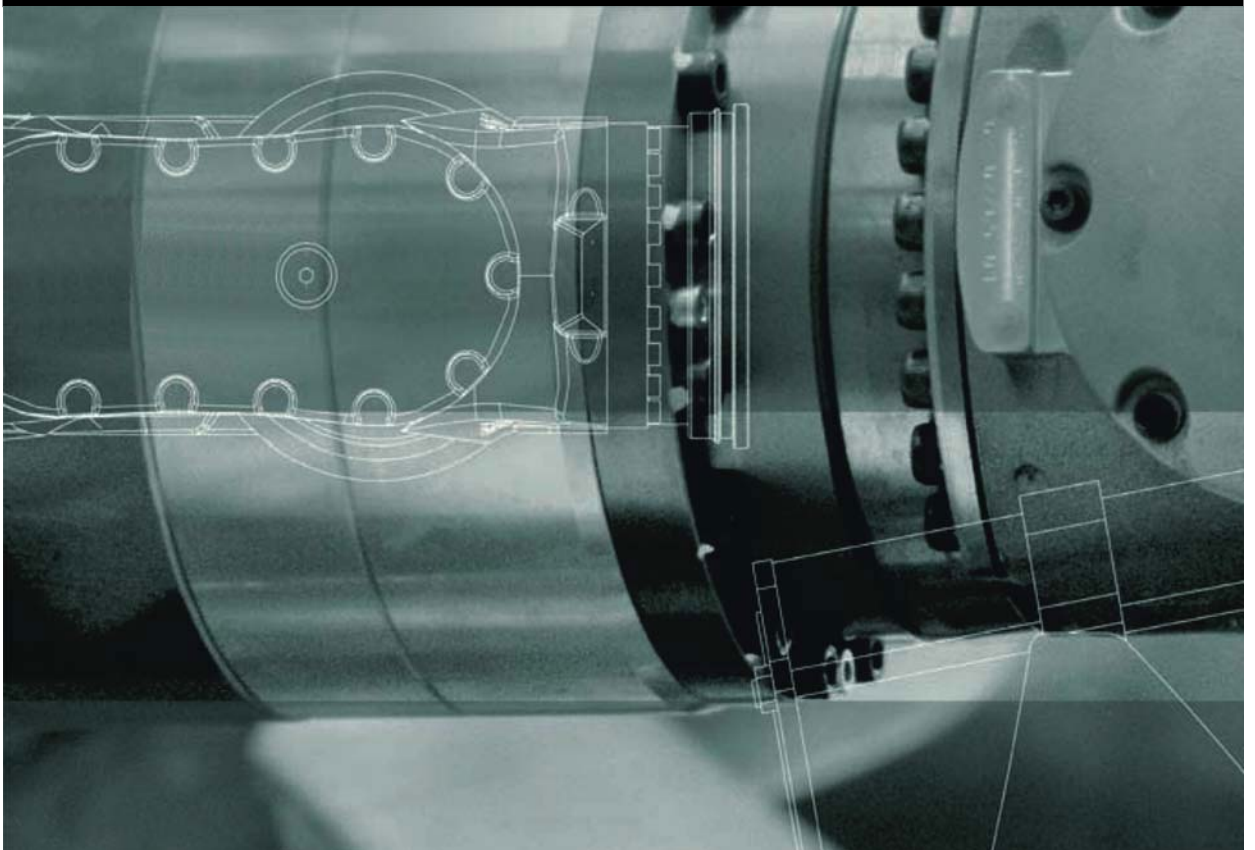

Issued: 23.05.2014

Version: Spez KR 5 arc V2



© Copyright 2014

KUKA Roboter GmbH  
Zugspitzstraße 140  
D-86165 Augsburg  
Germany

This documentation or excerpts therefrom may not be reproduced or disclosed to third parties without the express permission of KUKA Roboter GmbH.

Other functions not described in this documentation may be operable in the controller. The user has no claims to these functions, however, in the case of a replacement or service work.

We have checked the content of this documentation for conformity with the hardware and software described. Nevertheless, discrepancies cannot be precluded, for which reason we are not able to guarantee total conformity. The information in this documentation is checked on a regular basis, however, and necessary corrections will be incorporated in the subsequent edition.

Subject to technical alterations without an effect on the function.

Translation of the original documentation

KIM-PS5-DOC

Publication:	Pub Spez KR 5 arc en
Book structure:	Spez KR 5 arc V2.1
Version:	Spez KR 5 arc V2

## Contents

<b>1</b>	<b>Introduction</b>	<b>5</b>
1.1	Industrial robot documentation	5
1.2	Representation of warnings and notes	5
<b>2</b>	<b>Purpose</b>	<b>7</b>
2.1	Target group	7
2.2	Intended use	7
<b>3</b>	<b>Product description</b>	<b>9</b>
3.1	Overview of the robot system	9
3.2	Description of the robot	9
<b>4</b>	<b>Technical data</b>	<b>13</b>
4.1	Basic data	13
4.2	Axis data	14
4.3	Payloads	15
4.4	Loads acting on the mounting base	17
4.5	Plates and labels	18
4.6	Stopping distances and times, floor-mounted robots, KR 5 arc	19
4.6.1	Stopping distances and stopping times for STOP 0, axis 1 to axis 3	19
4.6.2	Stopping distances and stopping times for STOP 1, axis 1	21
4.6.3	Stopping distances and stopping times for STOP 1, axis 2	23
4.6.4	Stopping distances and stopping times for STOP 1, axis 3	25
4.7	Stopping distances and times, KR 5 arc-C	25
4.7.1	Stopping distances and stopping times for STOP 0, axis 1 to axis 3	25
4.7.2	Stopping distances and stopping times for STOP 1, axis 1	26
4.7.3	Stopping distances and stopping times for STOP 1, axis 2	28
4.7.4	Stopping distances and stopping times for STOP 1, axis 3	30
<b>5</b>	<b>Safety</b>	<b>31</b>
5.1	General	31
5.1.1	Liability	31
5.1.2	Intended use of the industrial robot	32
5.1.3	EC declaration of conformity and declaration of incorporation	32
5.1.4	Terms used	33
5.2	Personnel	33
5.3	Workspace, safety zone and danger zone	34
5.4	Overview of protective equipment	35
5.4.1	Mechanical end stops	35
5.4.2	Mechanical axis range limitation (optional)	35
5.4.3	Axis range monitoring (optional)	35
5.4.4	Options for moving the manipulator without drive energy	36
5.4.5	Labeling on the industrial robot	36
5.5	Safety measures	37
5.5.1	General safety measures	37
5.5.2	Transportation	38
5.5.3	Start-up and recommissioning	38
5.5.4	Manual mode	39

5.5.5	Automatic mode .....	40
5.5.6	Maintenance and repair .....	40
5.5.7	Decommissioning, storage and disposal .....	42
5.6	Applied norms and regulations .....	42
<b>6</b>	<b>Planning .....</b>	<b>45</b>
6.1	Information for planning .....	45
6.2	Mounting base with centering .....	45
6.3	Machine frame mounting with centering .....	48
6.4	Adapter plate .....	50
6.5	Connecting cables and interfaces .....	50
<b>7</b>	<b>Transportation .....</b>	<b>53</b>
7.1	Transporting the robot .....	53
<b>8</b>	<b>KUKA Service .....</b>	<b>57</b>
8.1	Requesting support .....	57
8.2	KUKA Customer Support .....	57
	<b>Index .....</b>	<b>65</b>

# 1 Introduction

## 1.1 Industrial robot documentation

The industrial robot documentation consists of the following parts:

- Documentation for the manipulator
- Documentation for the robot controller
- Operating and programming instructions for the System Software
- Instructions for options and accessories
- Parts catalog on storage medium

Each of these sets of instructions is a separate document.

## 1.2 Representation of warnings and notes

### Safety

These warnings are relevant to safety and **must** be observed.

 **DANGER** These warnings mean that it is certain or highly probable that death or severe injuries **will** occur, if no precautions are taken.

 **WARNING** These warnings mean that death or severe injuries **may** occur, if no precautions are taken.

 **CAUTION** These warnings mean that minor injuries **may** occur, if no precautions are taken.

 **NOTICE** These warnings mean that damage to property **may** occur, if no precautions are taken.

 These warnings contain references to safety-relevant information or general safety measures.  
These warnings do not refer to individual hazards or individual precautionary measures.

This warning draws attention to procedures which serve to prevent or remedy emergencies or malfunctions:

 **SAFETY INSTRUCTIONS** Procedures marked with this warning **must** be followed exactly.

### Notes

These notices serve to make your work easier or contain references to further information.

 Tip to make your work easier or reference to further information.



## 2 Purpose

### 2.1 Target group

This documentation is aimed at users with the following knowledge and skills:

- Advanced knowledge of mechanical engineering
- Advanced knowledge of electrical and electronic systems
- Knowledge of the robot controller system



For optimal use of our products, we recommend that our customers take part in a course of training at KUKA College. Information about the training program can be found at [www.kuka.com](http://www.kuka.com) or can be obtained directly from our subsidiaries.

### 2.2 Intended use

- Use**
- Handling of welding tools for arc welding
  - Handling of components in dry rooms

**Misuse** Any use or application deviating from the intended use is deemed to be misuse and is not allowed. This includes e.g.:

- Use as a climbing aid
- Operation outside the permissible operating parameters
- Use in potentially explosive environments
- Use in underground mining

**NOTICE**

Deviations from the operating conditions specified in the technical data or the use of special functions or applications can lead to premature wear. KUKA Roboter GmbH must be consulted.



The robot system is an integral part of a complete system and may only be operated in a CE-compliant system.





## 3 Product description

### 3.1 Overview of the robot system

The robot system consists of the following components:

- Robot
- Robot controller
- Cable set
- KCP teach pendant
- Software
- Options, accessories

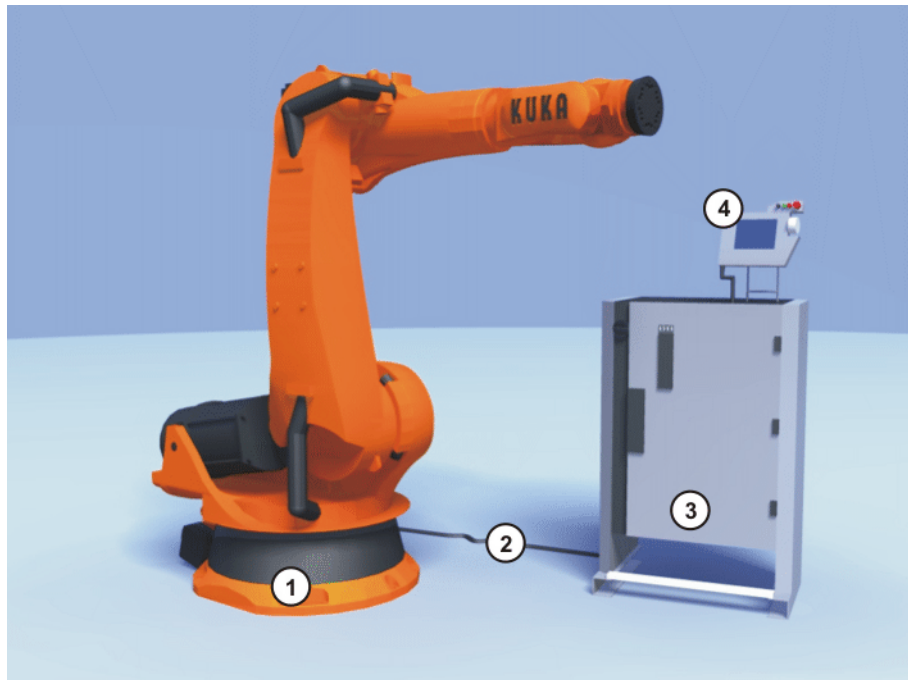

**Fig. 3-1: Example of an industrial robot**

- |   |           |   |                     |
|---|-----------|---|---------------------|
| 1 | Robot     | 3 | Robot controller    |
| 2 | Cable set | 4 | Teach pendant (KCP) |

#### SafeRobot

The SafeRobot option is available for this robot.

In this case the robot moves within limits that have been configured. The actual position is continuously calculated and monitored by the SafeRDC. If the robot violates a monitoring limit or a safety parameter, it is stopped.

#### RoboTeam

The RoboTeam option is available for this robot.

RoboTeam allows the operation of cooperating robot systems. In the RoboTeam, up to 15 robots can work together in a group. One robot in the group always takes on the role of “master”, while the remaining robots work as “slaves”.

### 3.2 Description of the robot

#### Overview

The robot is designed as a 6-axis jointed-arm kinematic system. It consists of the following principal components:

- In-line wrist
- Arm

- Link arm
- Rotating column
- Base frame
- Electrical installations



**Fig. 3-2: Main assemblies of the robot**

1	Arm	4	Base frame
2	In-line wrist	5	Link arm
3	Rotating column	6	Electrical installations

#### **In-line wrist**

The robot is fitted with a 3-axis in-line wrist. The in-line wrist contains axes 4, 5 and 6. For attaching end effectors (tools), the in-line wrist has a mounting flange.

#### **Arm**

The arm is the link between the in-line wrist and the link arm. It houses the motors of the wrist axes A 4, A 5 and A 6 and the motor of main axis A 3. The arm is driven by the motor of axis 3. The maximum permissible swivel angle is mechanically limited by a stop for each direction, plus and minus. The associated buffers are attached to the link arm.

#### **Link arm**

The link arm is the assembly located between the arm and the rotating column. It consists of the link arm body.

#### **Rotating column**

The rotating column houses the motors of axes 1 and 2. The rotational motion of axis 1 is performed by the rotating column. This is screwed to the base frame via the gear unit of axis 1 and is driven by a motor in the rotating column. The link arm is also mounted in the rotating column.

**Base frame**

The base frame is the base of the robot. It is screwed to the mounting base. The flexible tube for the electrical installations is fastened to the base frame. Also located on the base frame is the control cable junction box.



## 4 Technical data

### 4.1 Basic data

#### Basic data

Type	KR 5 arc
Number of axes	6
Volume of working envelope	8.4 m <sup>3</sup>
Pose repeatability (ISO 9283)	±0.04 mm
Working envelope reference point	Intersection of axes 4 and 5
Weight	approx. 127 kg
Principal dynamic loads	See "Loads acting on the mounting base" (>>> 4.4 "Loads acting on the mounting base" Page 17)
Protection rating of the robot	IP 54 Ready for operation, with connecting cables plugged in (according to EN 60529)
Protection rating of the in-line wrist	IP 65
Sound level	< 75 dB (A) outside the working envelope
Mounting position	Floor, ceiling
Surface finish, paintwork	Base frame (stationary) black (RAL 9005), moving parts: orange (RAL 2003)

#### Ambient temperature

Operation	283 K to 328 K (+10 °C to +55 °C)
Operation with Safe RDC	283 K to 323 K (+10 °C to +50 °C)
Storage and transportation	233 K to 333 K (-40 °C to +60 °C)
Start-up	283 K to 288 K (+10 °C to +15 °C) At these temperatures the robot may have to be warmed up before normal operation. Other temperature limits available on request.
Humidity rating	DIN EN 60721-3-3, Class 3K3

#### Connecting cables

The connecting cables are integrated into the robot's cable set and are plugged into the robot controller.

Cable designation	Connector designation robot controller - robot	Connection
Motor cable	X20 - X30	Han size 24
Control cable	X21 - X31	Circular connector
SafeRobot control cable	X21.1 - X41	Circular connector
Ground conductor		Ring cable lug

The length of the cables is measured from the base frame and the RDC box.

Cable lengths	
Standard	7 m, 10 m (optional), 15 m (optional)
with RoboTeam	7 m, 10 m (optional), 15 m (optional)
with SafeRobot	7 m, 10 m (optional), 15 m (optional)

For detailed specifications of the connecting cables, see .

## 4.2 Axis data

### Axis data

Axis	Range of motion, software-limited	Speed with rated payload
1	+/-155°	154 °/s
2	+65° to -180°	154 °/s
3	+158° to -15°	228 °/s
4	+/-350°	343 °/s
5	+/-130°	384 °/s
6	+/-350°	721 °/s

The direction of motion and the arrangement of the individual axes may be noted from the following diagram.

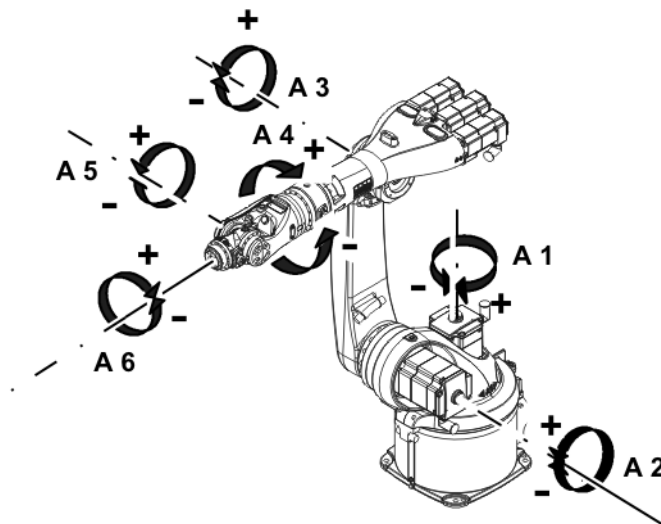

**Fig. 4-1: Direction of rotation of robot axes**

The diagram (>>> Fig. 4-2 ) shows the shape and size of the working envelope.

### Working envelope

The reference point for the working envelope is the intersection of axes 4 and 5.

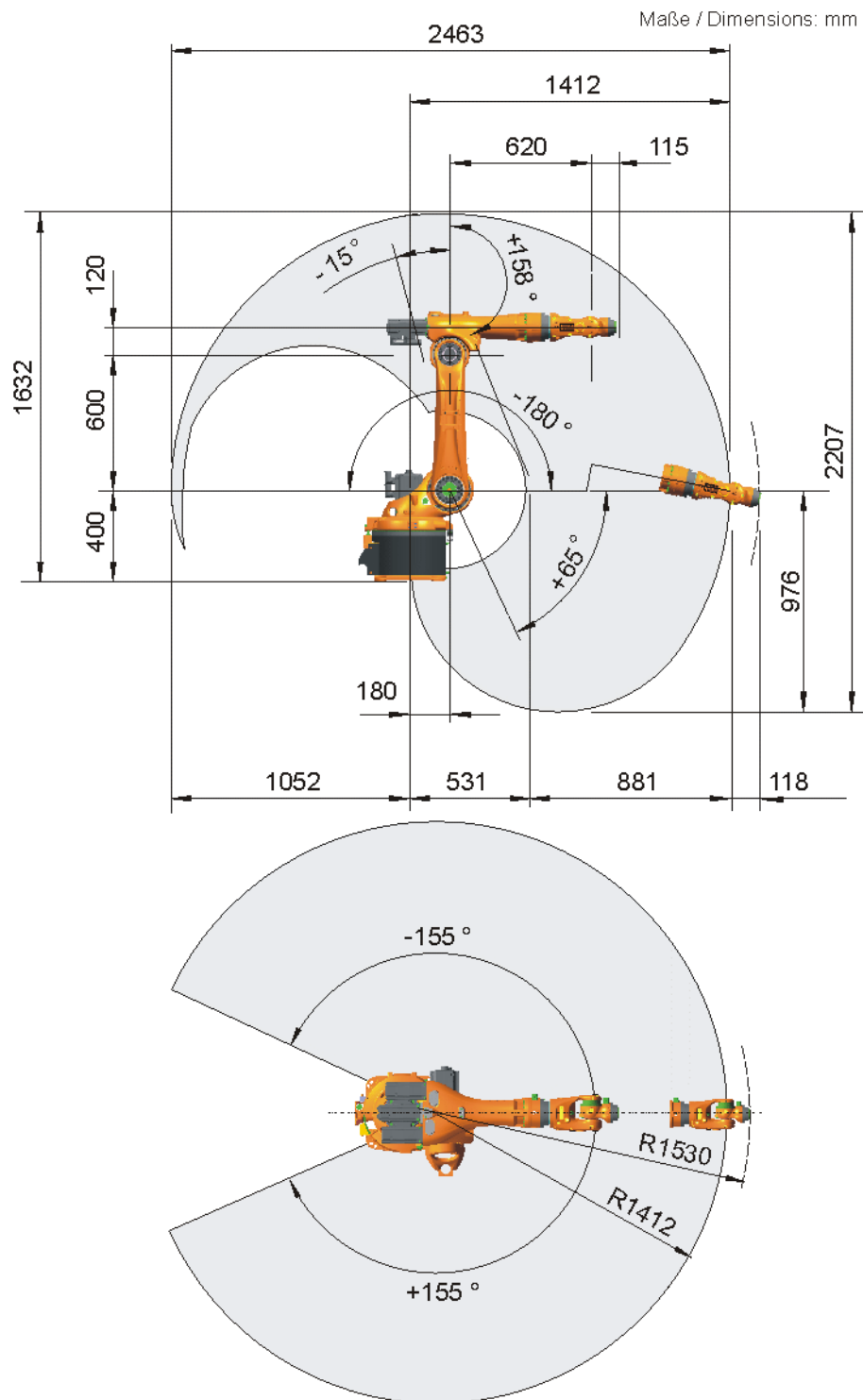

Fig. 4-2: Working envelope

### 4.3 Payloads

#### Payloads

Robot	KR 5 arc
In-line wrist	IW 5 arc
Rated payload	5 kg
Distance of the load center of gravity $L_z$ (vertical)	120 mm
Distance of the load center of gravity $L_{xy}$ (horizontal)	100 mm
Permissible mass moment of inertia	0.15 kgm <sup>2</sup>

Max. total load	37 kg
Supplementary load, arm	12 kg
Supplementary load, link arm	none
Supplementary load, rotating column	20 kg
Supplementary load, base frame	none

**Load center of gravity P**

For all payloads, the load center of gravity refers to the distance from the face of the mounting flange on axis 6. Refer to the payload diagram for the nominal distance.

**Payload diagram**

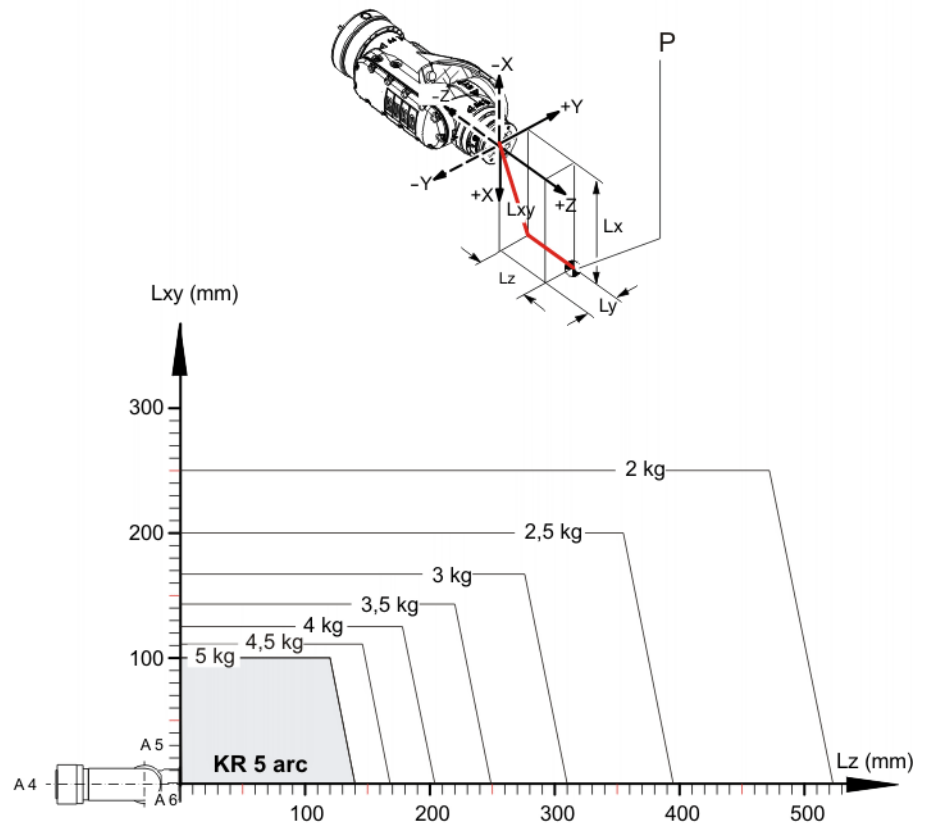

**Fig. 4-3: Payload diagram**

**NOTICE** This loading curve corresponds to the maximum load capacity. Both values (payload and mass moment of inertia) must be checked in all cases. Exceeding this capacity will reduce the service life of the robot and overload the motors and the gears; in any such case the KUKA Roboter GmbH must be consulted beforehand. The values determined here are necessary for planning the robot application. For commissioning the robot, additional input data are required in accordance with the operating and programming instructions of the KUKA System Software. The mass inertia must be verified using KUKA.Load. It is imperative for the load data to be entered in the robot controller!

**Mounting flange**

Mounting flange	DIN/ISO 9409-1-A40
Screw grade	10.9
Screw size	M6
Grip length	1.5 x nominal diameter
Depth of engagement	min. 6 mm, max. 9 mm
Locating element	6 <sup>H7</sup>



The mounting flange is depicted (>>> Fig. 4-4 ) with axes 4 and 6 in the zero position. The symbol  $X_m$  indicates the position of the locating element (bushing) in the zero position.

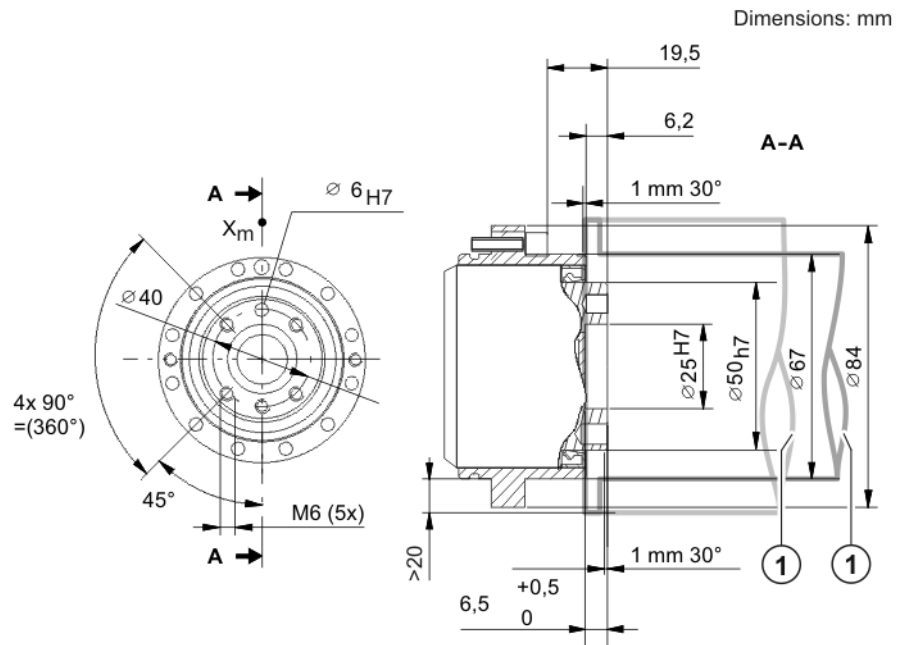
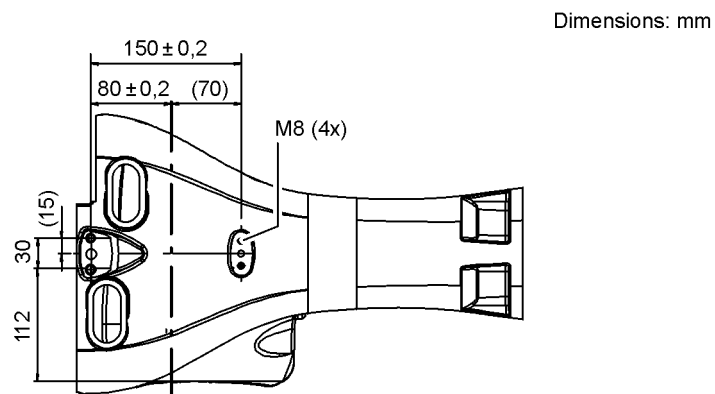

**Fig. 4-4: Mounting flange**

- 1 Recommended contour for the tool holder

#### Supplementary load

The robot can carry supplementary loads on the arm. When mounting the supplementary loads, be careful to observe the maximum permissible total load. The dimensions and positions of the installation options can be seen in the following diagram.



**Fig. 4-5: Supplementary load on arm**

#### 4.4 Loads acting on the mounting base

##### Loads acting on the mounting base

The specified forces and moments already include the payload and the inertia force (weight) of the robot.

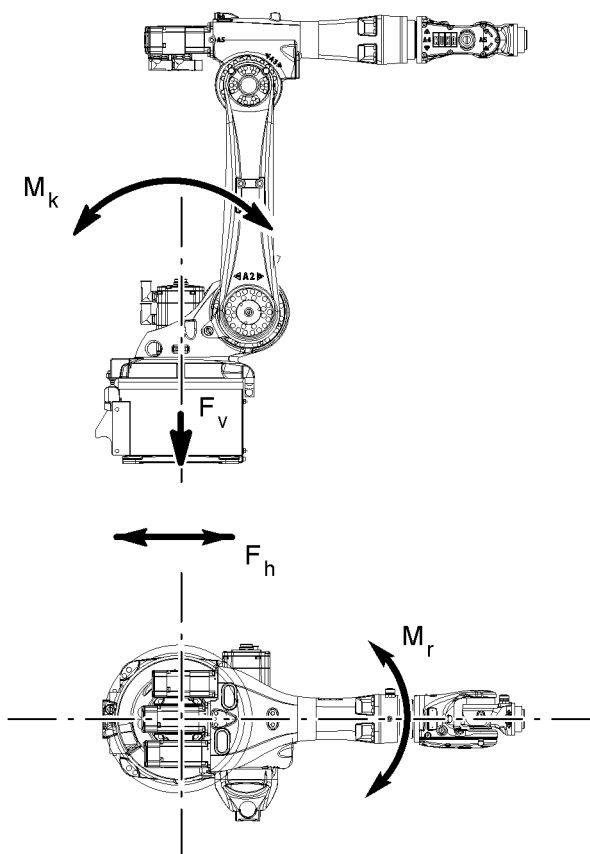

Fig. 4-6: Loads acting on the mounting base

Type of load	Force/torque/mass
$F_v$ = vertical force	$F_{vmax} = 2,132 \text{ N}$
$F_h$ = horizontal force	$F_{hmax} = 2,033 \text{ N}$
$M_k$ = tilting moment	$M_{kmax} = 1,918 \text{ Nm}$
$M_r$ = torque	$M_{rmax} = 1,671 \text{ Nm}$
Total mass for load acting on the mounting base	144 kg
Robot	127 kg
Total load (suppl. load on arm + rated payload)	17 kg

**NOTICE** The foundation loads specified in the table are the maximum loads that may occur. They must be referred to when dimensioning the foundations and must be adhered to for safety reasons. Failure to do so may result in material damage. The supplementary loads are not taken into consideration in the calculation of the foundation load. These supplementary loads must be taken into consideration for  $F_v$ .

#### 4.5 Plates and labels

**Plates and labels** The following plates and labels are attached to the robot. They must not be removed or rendered illegible. Illegible plates and labels must be replaced.

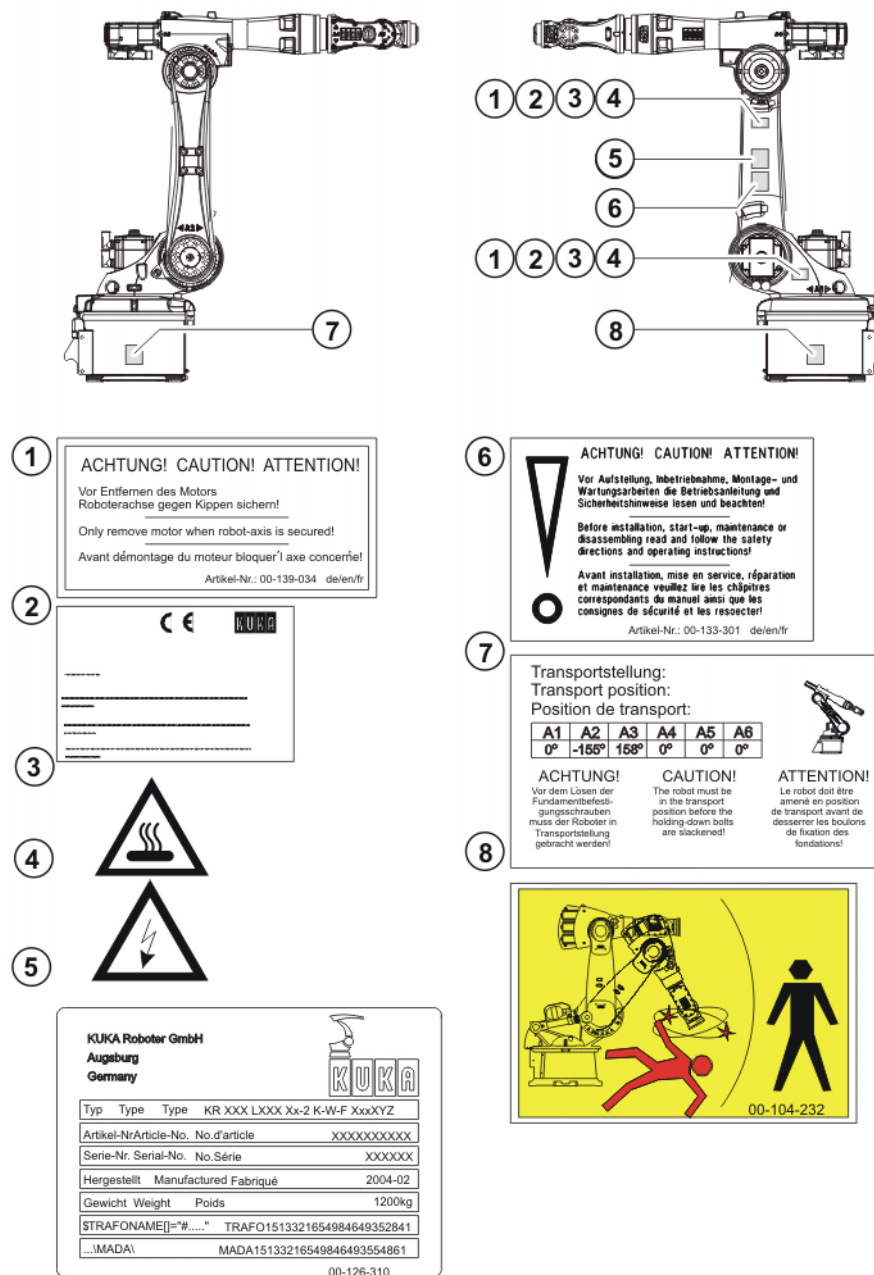

Fig. 4-7: Plates and labels

## 4.6 Stopping distances and times, floor-mounted robots, KR 5 arc

### 4.6.1 Stopping distances and stopping times for STOP 0, axis 1 to axis 3

The table shows the stopping distances and stopping times after a STOP 0 (category 0 stop) is triggered. The values refer to the following configuration:

- Extension l = 100%
- Program override POV = 100%
- Mass m = maximum load (rated load + supplementary load on arm)

	Stopping distance (°)	Stopping time (s)
Axis 1	33.93	0.280

	Stopping distance (°)	Stopping time (s)
Axis 2	37.19	0.301
Axis 3	60.60	0.333

## 4.6.2 Stopping distances and stopping times for STOP 1, axis 1

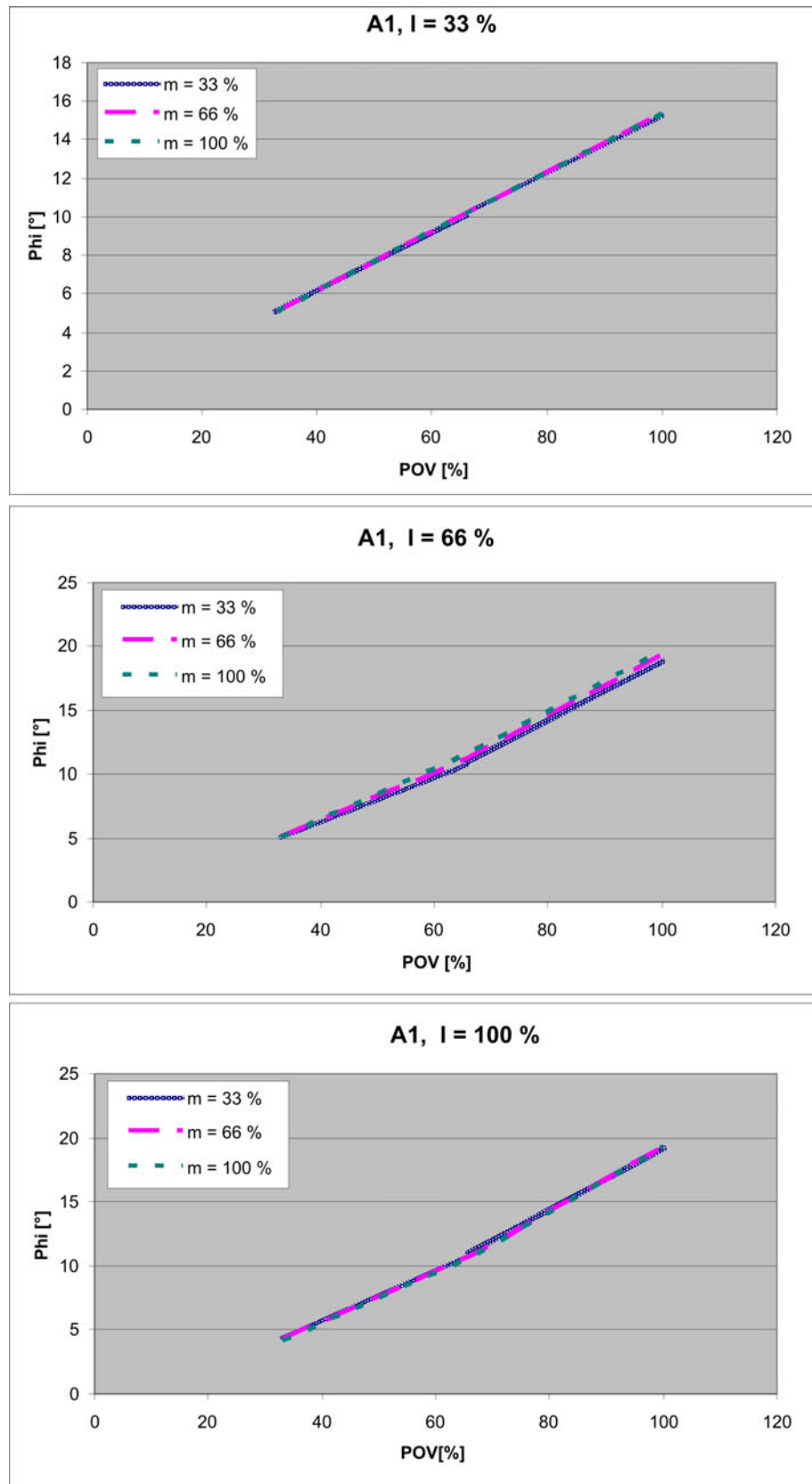

Fig. 4-8: Stopping distances for STOP 1, axis 1

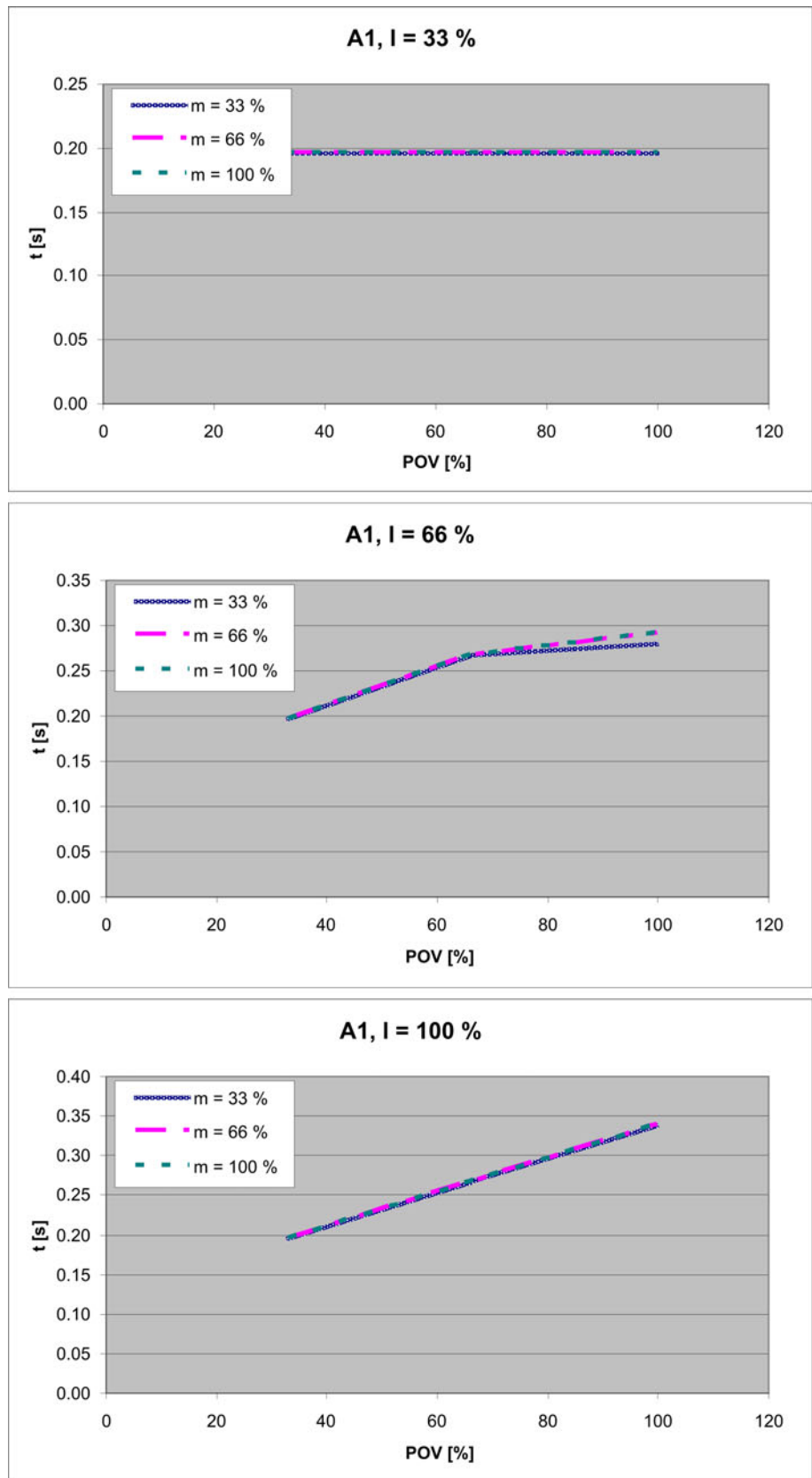

Fig. 4-9: Stopping times for STOP 1, axis 1

## 4.6.3 Stopping distances and stopping times for STOP 1, axis 2

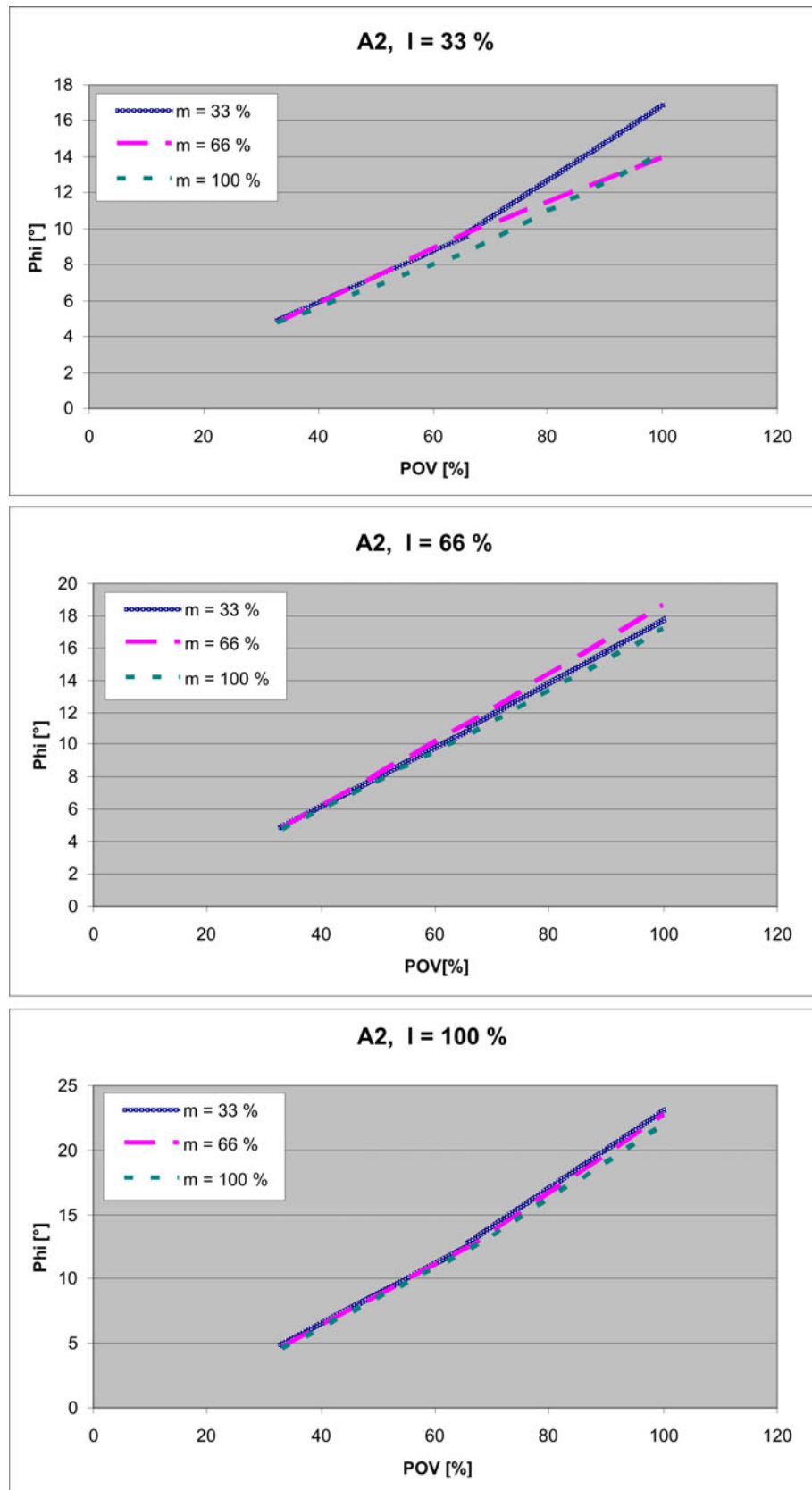

Fig. 4-10: Stopping distances for STOP 1, axis 2

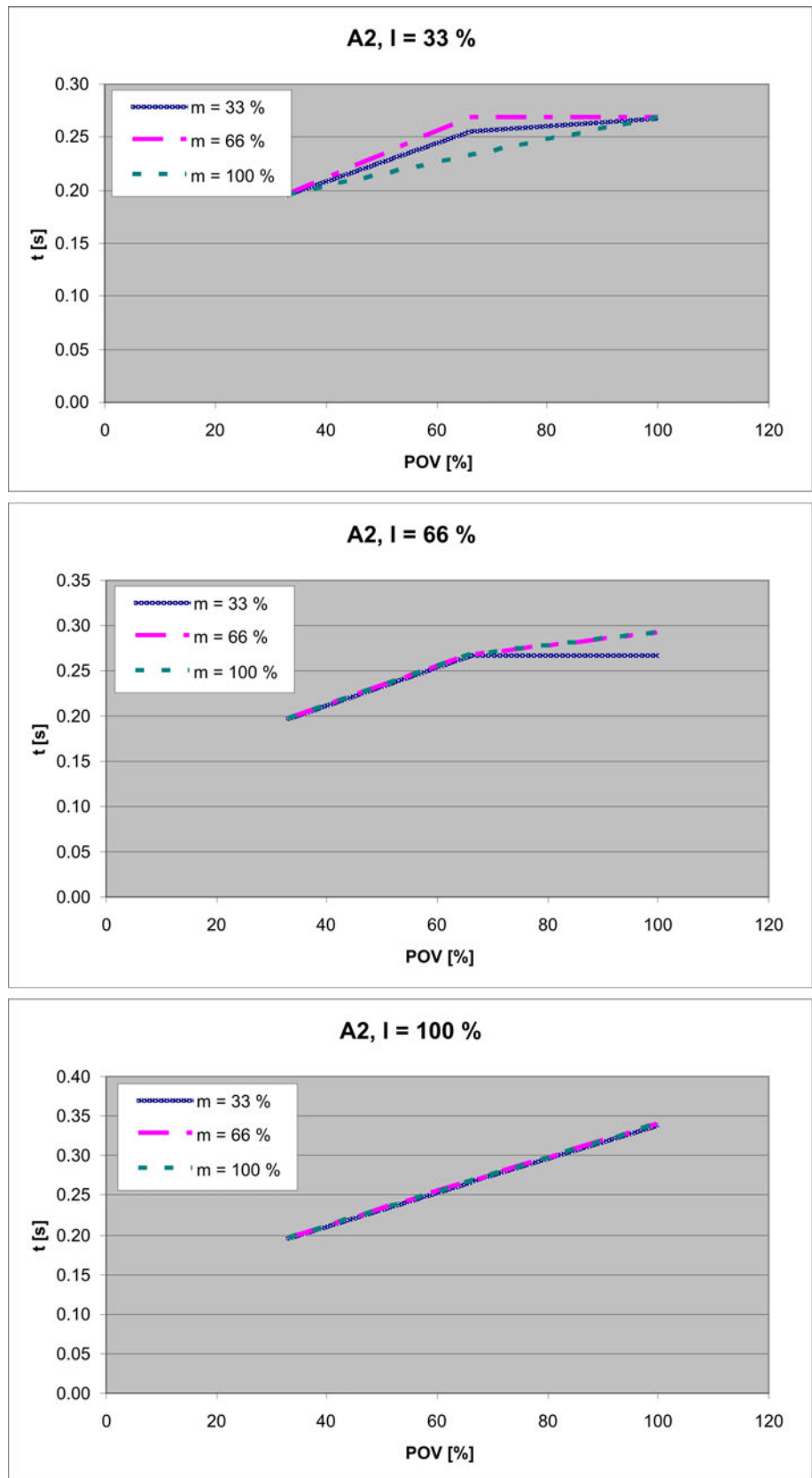

Fig. 4-11: Stopping times for STOP 1, axis 2



#### 4.6.4 Stopping distances and stopping times for STOP 1, axis 3

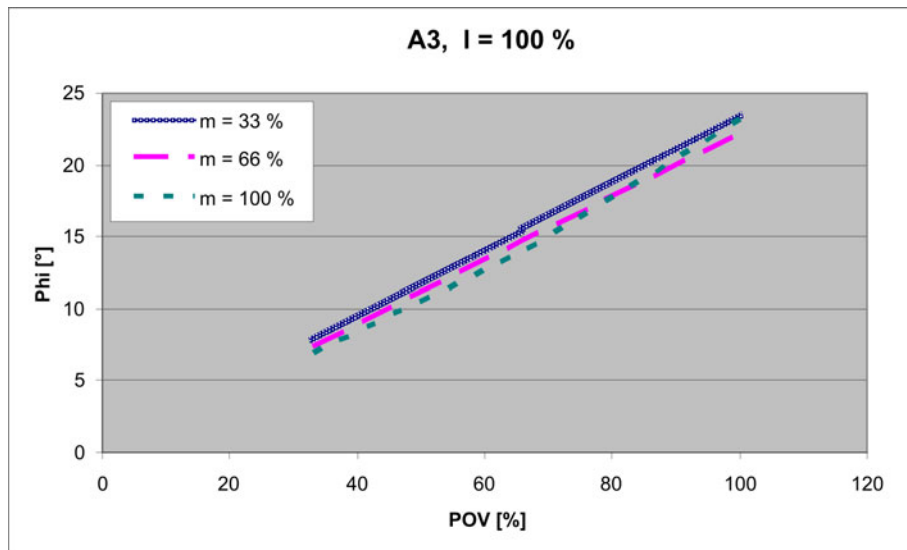

Fig. 4-12: Stopping distances for STOP 1, axis 3

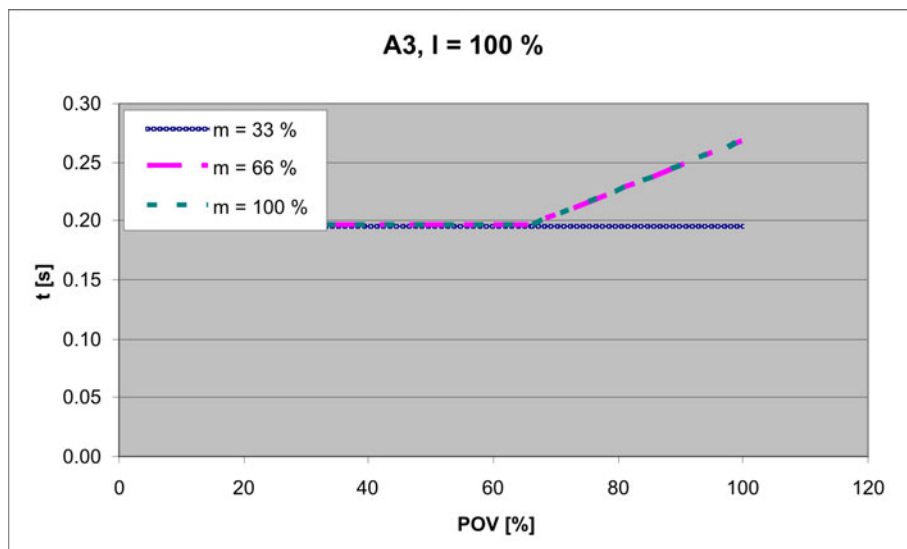

Fig. 4-13: Stopping times for STOP 1, axis 3

#### 4.7 Stopping distances and times, KR 5 arc-C

##### 4.7.1 Stopping distances and stopping times for STOP 0, axis 1 to axis 3

The table shows the stopping distances and stopping times after a STOP 0 (category 0 stop) is triggered. The values refer to the following configuration:

- Extension I = 100%
- Program override POV = 100%
- Mass m = maximum load (rated load + supplementary load on arm)

	Stopping distance (°)	Stopping time (s)
Axis 1	33.97	0.280
Axis 2	37.00	0.286
Axis 3	57.82	0.308

4.7.2 Stopping distances and stopping times for STOP 1, axis 1

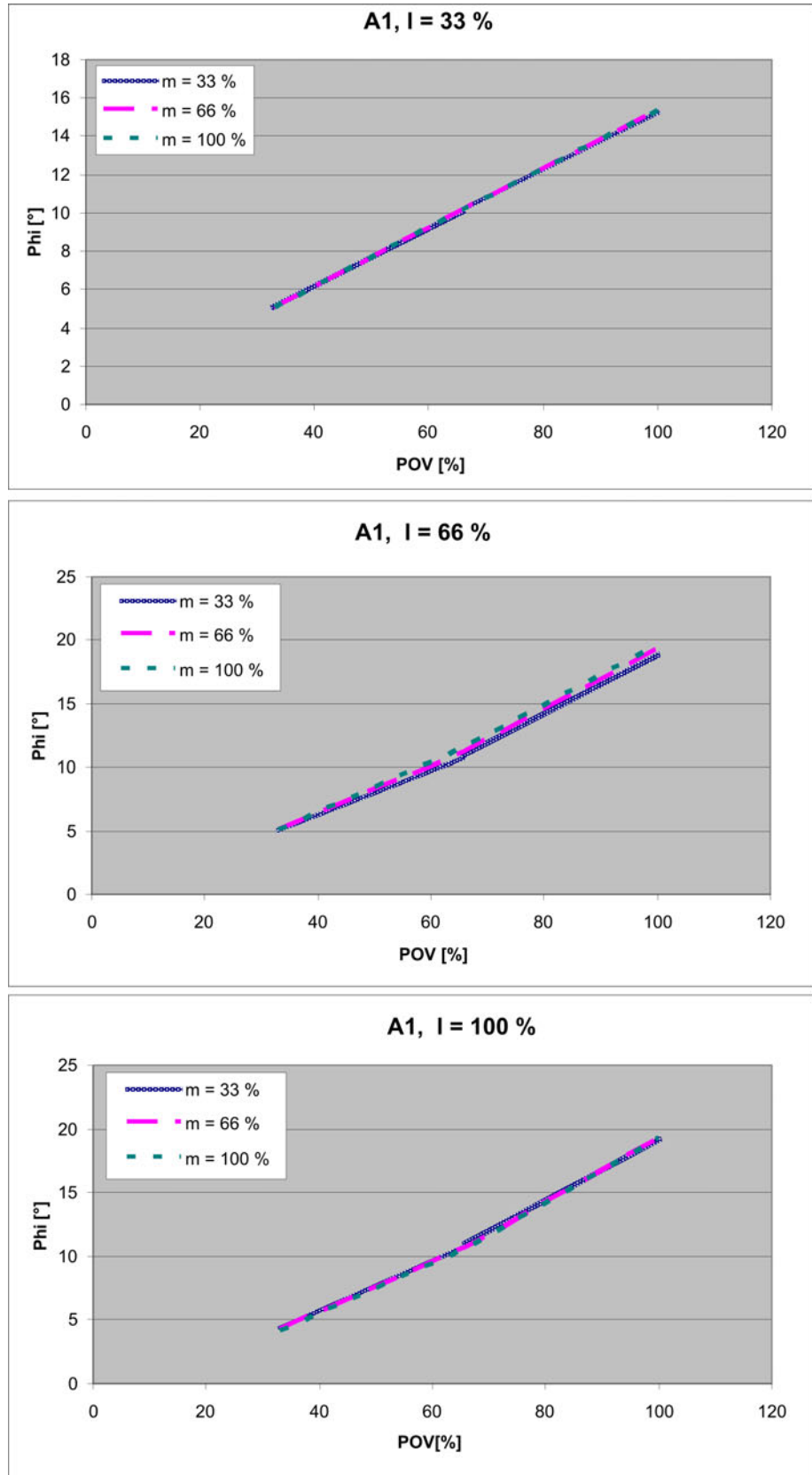

Fig. 4-14: Stopping distances for STOP 1, axis 1

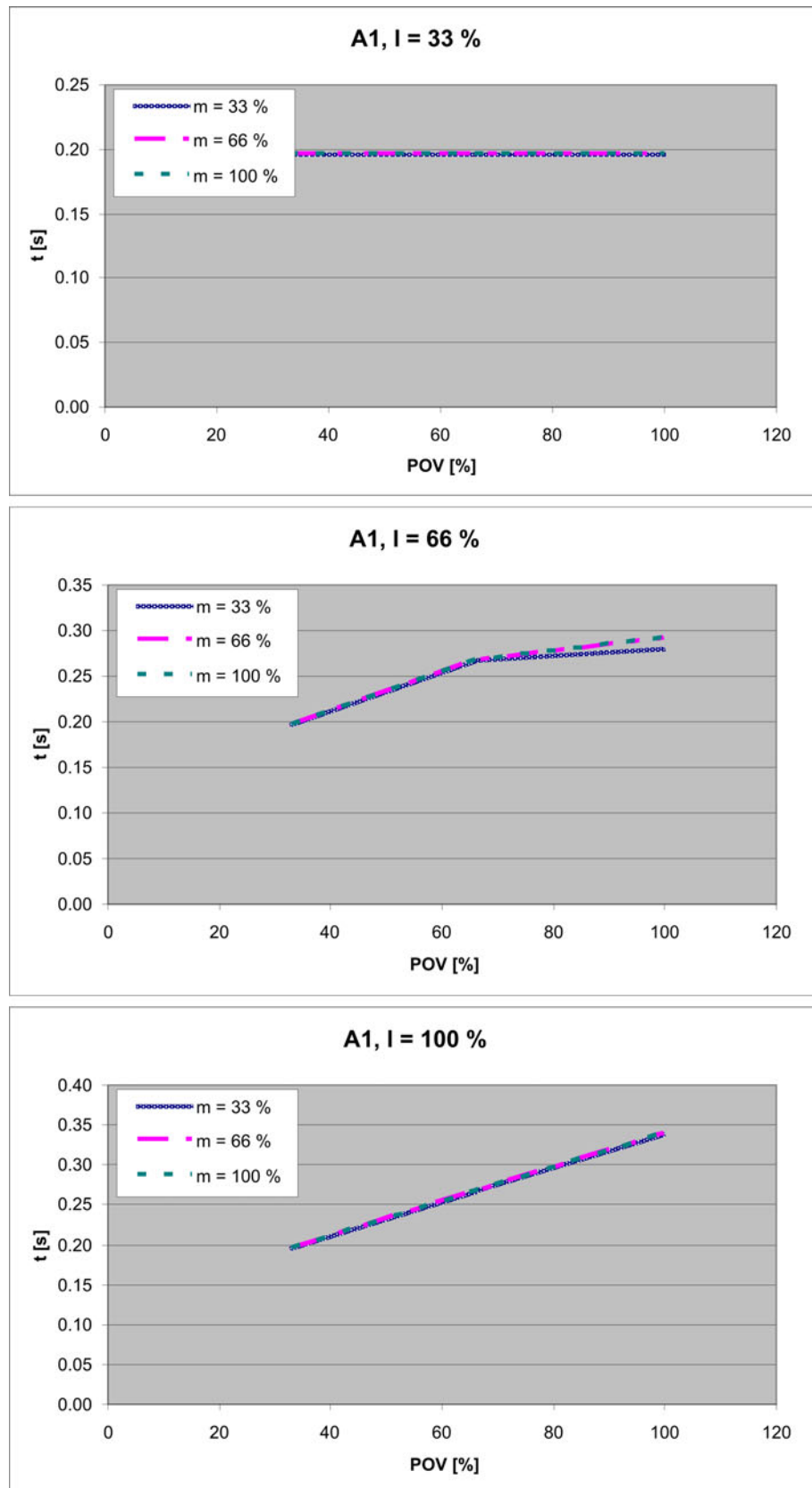

Fig. 4-15: Stopping times for STOP 1, axis 1

4.7.3 Stopping distances and stopping times for STOP 1, axis 2

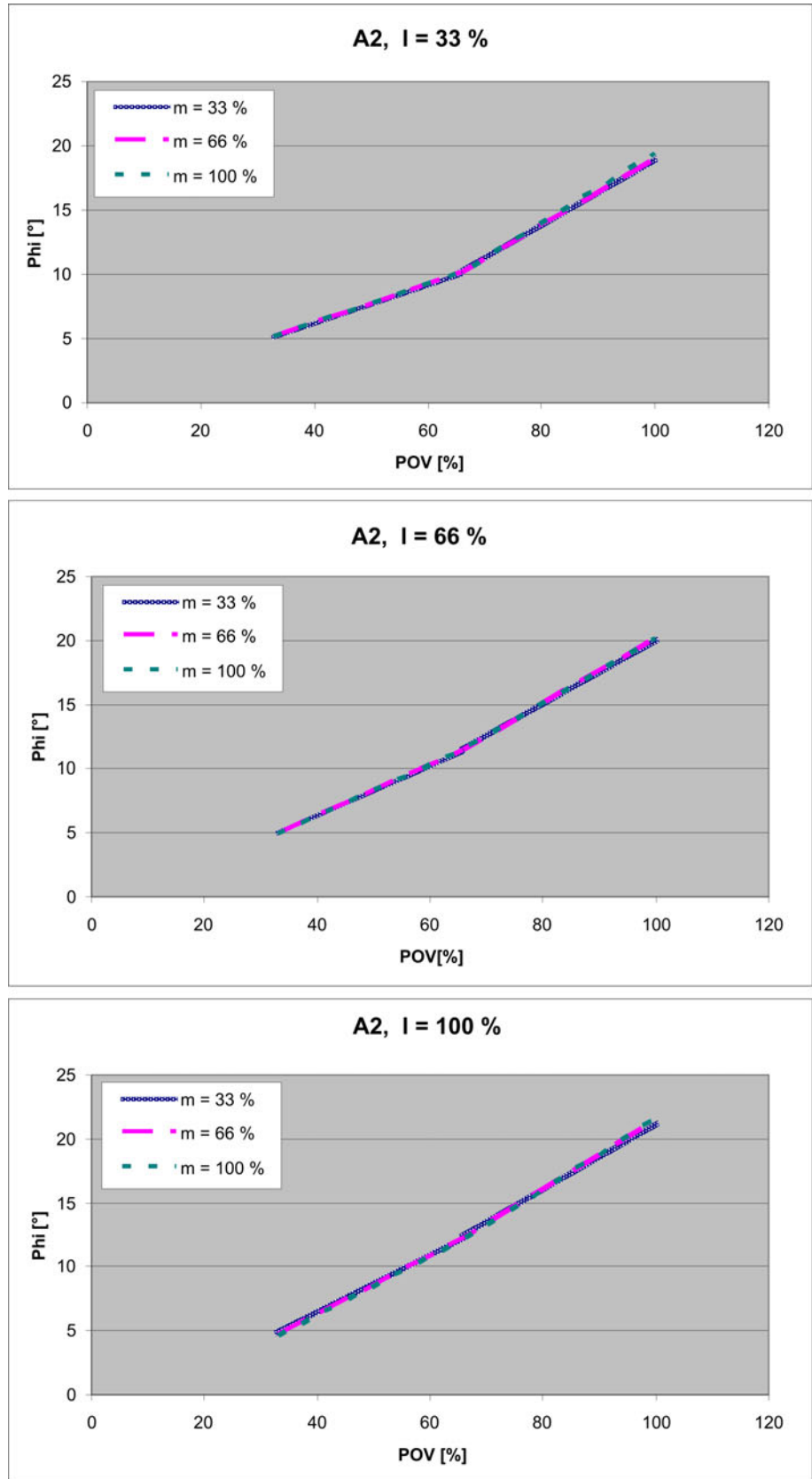

Fig. 4-16: Stopping distances for STOP 1, axis 2

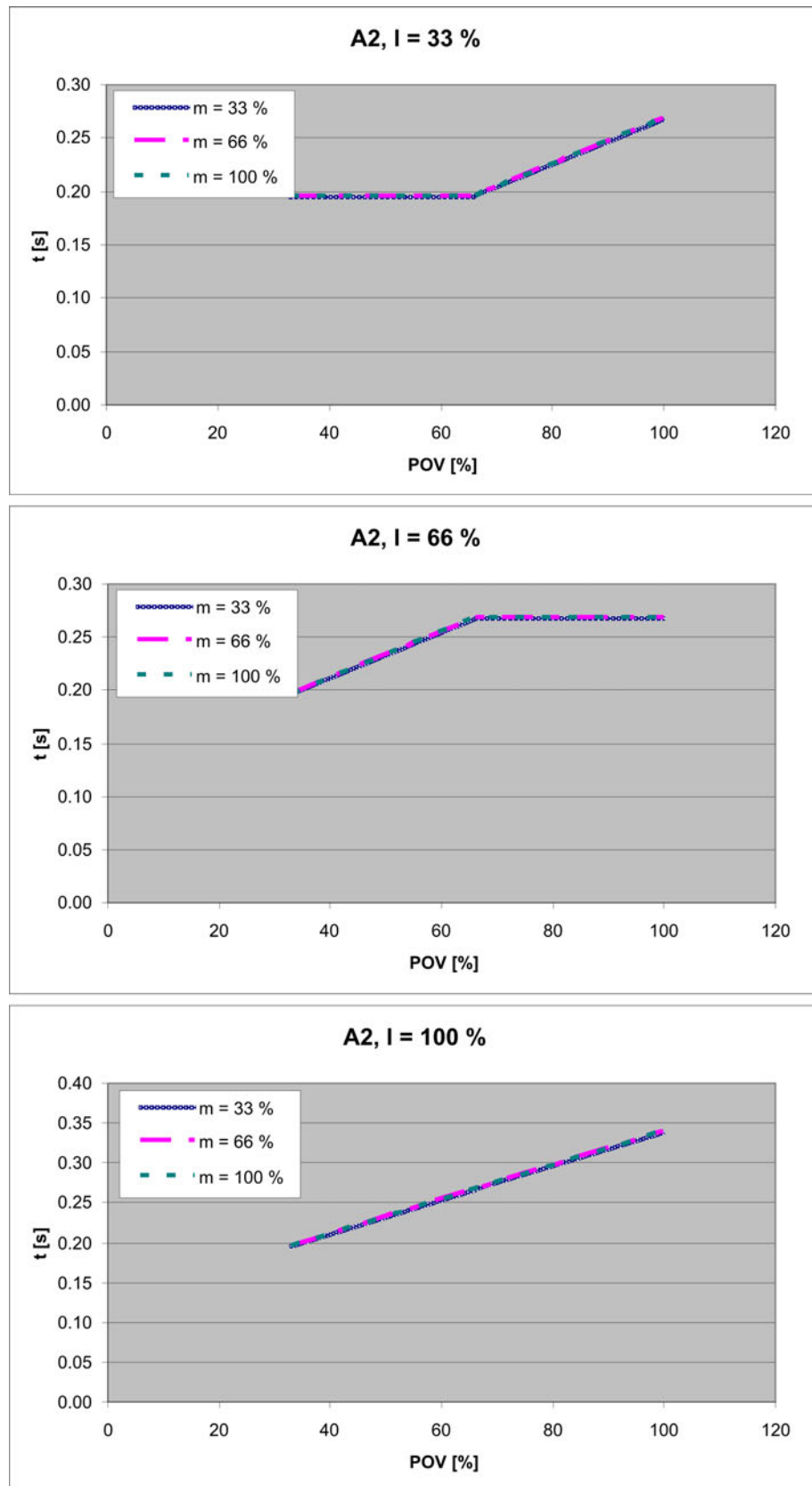

Fig. 4-17: Stopping times for STOP 1, axis 2

4.7.4 Stopping distances and stopping times for STOP 1, axis 3

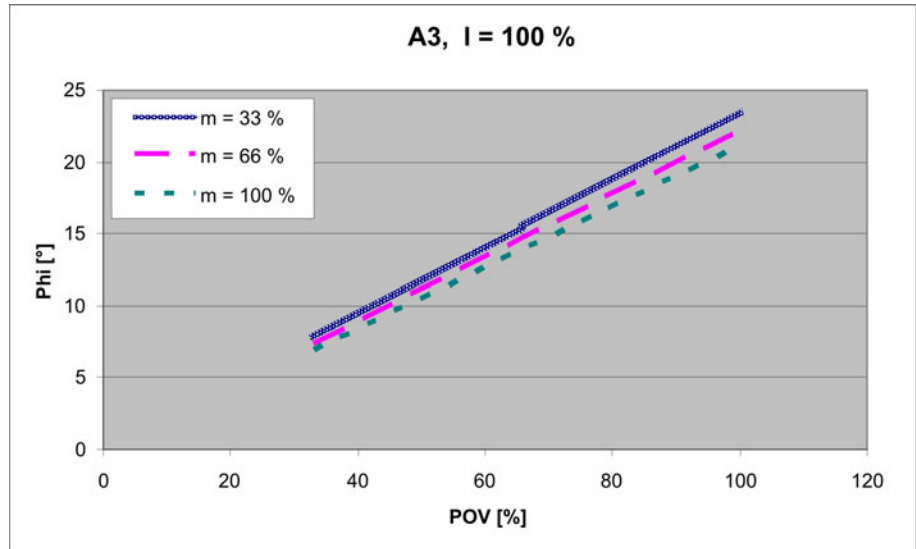

Fig. 4-18: Stopping distances for STOP 1, axis 3

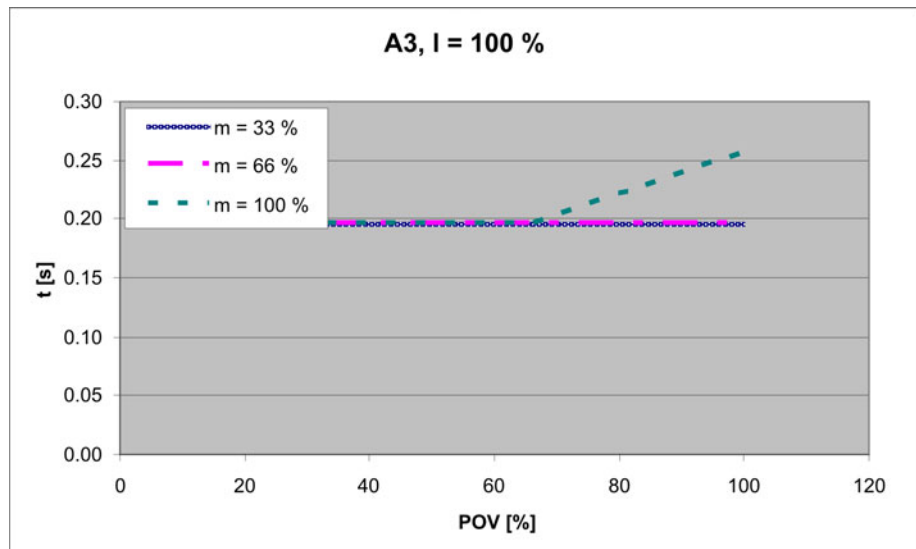

Fig. 4-19: Stopping times for STOP 1, axis 3

## 5 Safety

### 5.1 General



■ This “Safety” chapter refers to a mechanical component of an industrial robot.

■ If the mechanical component is used together with a KUKA robot controller, the “Safety” chapter of the operating instructions or assembly instructions of the robot controller must be used!

This contains all the information provided in this “Safety” chapter. It also contains additional safety information relating to the robot controller which must be observed.

■ Where this “Safety” chapter uses the term “industrial robot”, this also refers to the individual mechanical component if applicable.

#### 5.1.1 Liability

The device described in this document is either an industrial robot or a component thereof.

Components of the industrial robot:

- Manipulator
- Robot controller
- Teach pendant
- Connecting cables
- External axes (optional)  
e.g. linear unit, turn-tilt table, positioner
- Software
- Options, accessories

The industrial robot is built using state-of-the-art technology and in accordance with the recognized safety rules. Nevertheless, misuse of the industrial robot may constitute a risk to life and limb or cause damage to the industrial robot and to other material property.

The industrial robot may only be used in perfect technical condition in accordance with its designated use and only by safety-conscious persons who are fully aware of the risks involved in its operation. Use of the industrial robot is subject to compliance with this document and with the declaration of incorporation supplied together with the industrial robot. Any functional disorders affecting safety must be rectified immediately.

#### Safety information

Safety information cannot be held against KUKA Roboter GmbH. Even if all safety instructions are followed, this is not a guarantee that the industrial robot will not cause personal injuries or material damage.

No modifications may be carried out to the industrial robot without the authorization of KUKA Roboter GmbH. Additional components (tools, software, etc.), not supplied by KUKA Roboter GmbH, may be integrated into the industrial robot. The user is liable for any damage these components may cause to the industrial robot or to other material property.

In addition to the Safety chapter, this document contains further safety instructions. These must also be observed.

### 5.1.2 Intended use of the industrial robot

The industrial robot is intended exclusively for the use designated in the "Purpose" chapter of the operating instructions or assembly instructions.

Any use or application deviating from the intended use is deemed to be misuse and is not allowed. The manufacturer is not liable for any damage resulting from such misuse. The risk lies entirely with the user.

Operation of the industrial robot in accordance with its intended use also requires compliance with the operating and assembly instructions for the individual components, with particular reference to the maintenance specifications.

#### Misuse

Any use or application deviating from the intended use is deemed to be misuse and is not allowed. This includes e.g.:

- Transportation of persons and animals
- Use as a climbing aid
- Operation outside the specified operating parameters
- Use in potentially explosive environments
- Operation without additional safeguards
- Outdoor operation
- Underground operation

### 5.1.3 EC declaration of conformity and declaration of incorporation

The industrial robot constitutes partly completed machinery as defined by the EC Machinery Directive. The industrial robot may only be put into operation if the following preconditions are met:

- The industrial robot is integrated into a complete system.  
Or: The industrial robot, together with other machinery, constitutes a complete system.  
Or: All safety functions and safeguards required for operation in the complete machine as defined by the EC Machinery Directive have been added to the industrial robot.
- The complete system complies with the EC Machinery Directive. This has been confirmed by means of an assessment of conformity.

#### Declaration of conformity

The system integrator must issue a declaration of conformity for the complete system in accordance with the Machinery Directive. The declaration of conformity forms the basis for the CE mark for the system. The industrial robot must always be operated in accordance with the applicable national laws, regulations and standards.

The robot controller is CE certified under the EMC Directive and the Low Voltage Directive.

#### Declaration of incorporation

The industrial robot as partly completed machinery is supplied with a declaration of incorporation in accordance with Annex II B of the EC Machinery Directive 2006/42/EC. The assembly instructions and a list of essential requirements complied with in accordance with Annex I are integral parts of this declaration of incorporation.

The declaration of incorporation declares that the start-up of the partly completed machinery is not allowed until the partly completed machinery has been incorporated into machinery, or has been assembled with other parts to form machinery, and this machinery complies with the terms of the EC Machinery Directive, and the EC declaration of conformity is present in accordance with Annex II A.



### 5.1.4 Terms used

Term	Description
Axis range	Range of each axis, in degrees or millimeters, within which it may move. The axis range must be defined for each axis.
Stopping distance	Stopping distance = reaction distance + braking distance The stopping distance is part of the danger zone.
Workspace	The manipulator is allowed to move within its workspace. The workspace is derived from the individual axis ranges.
Operator (User)	The user of the industrial robot can be the management, employer or delegated person responsible for use of the industrial robot.
Danger zone	The danger zone consists of the workspace and the stopping distances.
Service life	The service life of a safety-relevant component begins at the time of delivery of the component to the customer.  The service life is not affected by whether the component is used in a robot controller or elsewhere or not, as safety-relevant components are also subject to aging during storage.
KCP	KUKA Control Panel  Teach pendant for the KR C2/KR C2 edition2005  The KCP has all the operator control and display functions required for operating and programming the industrial robot.
KUKA smartPAD	see "smartPAD"
Manipulator	The robot arm and the associated electrical installations
Safety zone	The safety zone is situated outside the danger zone.
smartPAD	Teach pendant for the KR C4  The smartPAD has all the operator control and display functions required for operating and programming the industrial robot.
Stop category 0	The drives are deactivated immediately and the brakes are applied. The manipulator and any external axes (optional) perform path-oriented braking.  <b>Note:</b> This stop category is called STOP 0 in this document.
Stop category 1	The manipulator and any external axes (optional) perform path-maintaining braking. The drives are deactivated after 1 s and the brakes are applied.  <b>Note:</b> This stop category is called STOP 1 in this document.
Stop category 2	The drives are not deactivated and the brakes are not applied. The manipulator and any external axes (optional) are braked with a normal braking ramp.  <b>Note:</b> This stop category is called STOP 2 in this document.
System integrator (plant integrator)	System integrators are people who safely integrate the industrial robot into a complete system and commission it.
T1	Test mode, Manual Reduced Velocity ( $\leq 250$ mm/s)
T2	Test mode, Manual High Velocity ( $> 250$ mm/s permissible)
External axis	Motion axis which is not part of the manipulator but which is controlled using the robot controller, e.g. KUKA linear unit, turn-tilt table, Posiflex.

## 5.2 Personnel

The following persons or groups of persons are defined for the industrial robot:

- User

- Personnel



All persons working with the industrial robot must have read and understood the industrial robot documentation, including the safety chapter.

**User**

The user must observe the labor laws and regulations. This includes e.g.:

- The user must comply with his monitoring obligations.
- The user must carry out instructions at defined intervals.

**Personnel**

Personnel must be instructed, before any work is commenced, in the type of work involved and what exactly it entails as well as any hazards which may exist. Instruction must be carried out regularly. Instruction is also required after particular incidents or technical modifications.

Personnel includes:

- System integrator
- Operators, subdivided into:
  - Start-up, maintenance and service personnel
  - Operating personnel
  - Cleaning personnel



Installation, exchange, adjustment, operation, maintenance and repair must be performed only as specified in the operating or assembly instructions for the relevant component of the industrial robot and only by personnel specially trained for this purpose.

**System integrator**

The industrial robot is safely integrated into a complete system by the system integrator.

The system integrator is responsible for the following tasks:

- Installing the industrial robot
- Connecting the industrial robot
- Performing risk assessment
- Implementing the required safety functions and safeguards
- Issuing the declaration of conformity
- Attaching the CE mark
- Creating the operating instructions for the complete system

**Operator**

The operator must meet the following preconditions:

- The operator must be trained for the work to be carried out.
- Work on the industrial robot must only be carried out by qualified personnel. These are people who, due to their specialist training, knowledge and experience, and their familiarization with the relevant standards, are able to assess the work to be carried out and detect any potential hazards.



Work on the electrical and mechanical equipment of the industrial robot may only be carried out by specially trained personnel.

### 5.3 Workspace, safety zone and danger zone

Workspaces are to be restricted to the necessary minimum size. A workspace must be safeguarded using appropriate safeguards.

The safeguards (e.g. safety gate) must be situated inside the safety zone. In the case of a stop, the manipulator and external axes (optional) are braked and come to a stop within the danger zone.

The danger zone consists of the workspace and the stopping distances of the manipulator and external axes (optional). It must be safeguarded by means of physical safeguards to prevent danger to persons or the risk of material damage.

## 5.4 Overview of protective equipment

The protective equipment of the mechanical component may include:

- Mechanical end stops
- Mechanical axis range limitation (optional)
- Axis range monitoring (optional)
- Release device (optional)
- Labeling of danger areas

Not all equipment is relevant for every mechanical component.

### 5.4.1 Mechanical end stops

Depending on the robot variant, the axis ranges of the main and wrist axes of the manipulator are partially limited by mechanical end stops.

Additional mechanical end stops can be installed on the external axes.

 **WARNING** If the manipulator or an external axis hits an obstruction or a mechanical end stop or axis range limitation, the manipulator can no longer be operated safely. The manipulator must be taken out of operation and KUKA Roboter GmbH must be consulted before it is put back into operation (>>> 8 "KUKA Service" Page 57).

### 5.4.2 Mechanical axis range limitation (optional)

Some manipulators can be fitted with mechanical axis range limitation in axes A1 to A3. The adjustable axis range limitation systems restrict the working range to the required minimum. This increases personal safety and protection of the system.

In the case of manipulators that are not designed to be fitted with mechanical axis range limitation, the workspace must be laid out in such a way that there is no danger to persons or material property, even in the absence of mechanical axis range limitation.

If this is not possible, the workspace must be limited by means of photoelectric barriers, photoelectric curtains or obstacles on the system side. There must be no shearing or crushing hazards at the loading and transfer areas.

 This option is not available for all robot models. Information on specific robot models can be obtained from KUKA Roboter GmbH.

### 5.4.3 Axis range monitoring (optional)

Some manipulators can be fitted with dual-channel axis range monitoring systems in main axes A1 to A3. The positioner axes may be fitted with additional axis range monitoring systems. The safety zone for an axis can be adjusted

and monitored using an axis range monitoring system. This increases personal safety and protection of the system.



This option is not available for the KR C4. This option is not available for all robot models. Information on specific robot models can be obtained from KUKA Roboter GmbH.

#### 5.4.4 Options for moving the manipulator without drive energy



The system user is responsible for ensuring that the training of personnel with regard to the response to emergencies or exceptional situations also includes how the manipulator can be moved without drive energy.

##### Description

The following options are available for moving the manipulator without drive energy after an accident or malfunction:

- Release device (optional)  
The release device can be used for the main axis drive motors and, depending on the robot variant, also for the wrist axis drive motors.
- Brake release device (option)  
The brake release device is designed for robot variants whose motors are not freely accessible.
- Moving the wrist axes directly by hand  
There is no release device available for the wrist axes of variants in the low payload category. This is not necessary because the wrist axes can be moved directly by hand.



Information about the options available for the various robot models and about how to use them can be found in the assembly and operating instructions for the robot or requested from KUKA Roboter GmbH.

##### **NOTICE**

Moving the manipulator without drive energy can damage the motor brakes of the axes concerned. The motor must be replaced if the brake has been damaged. The manipulator may therefore be moved without drive energy only in emergencies, e.g. for rescuing persons.

#### 5.4.5 Labeling on the industrial robot

All plates, labels, symbols and marks constitute safety-relevant parts of the industrial robot. They must not be modified or removed.

Labeling on the industrial robot consists of:

- Identification plates
- Warning signs
- Safety symbols
- Designation labels
- Cable markings
- Rating plates



Further information is contained in the technical data of the operating instructions or assembly instructions of the components of the industrial robot.

## 5.5 Safety measures

### 5.5.1 General safety measures

The industrial robot may only be used in perfect technical condition in accordance with its intended use and only by safety-conscious persons. Operator errors can result in personal injury and damage to property.

It is important to be prepared for possible movements of the industrial robot even after the robot controller has been switched off and locked out. Incorrect installation (e.g. overload) or mechanical defects (e.g. brake defect) can cause the manipulator or external axes to sag. If work is to be carried out on a switched-off industrial robot, the manipulator and external axes must first be moved into a position in which they are unable to move on their own, whether the payload is mounted or not. If this is not possible, the manipulator and external axes must be secured by appropriate means.

**⚠ DANGER** In the absence of operational safety functions and safeguards, the industrial robot can cause personal injury or material damage. If safety functions or safeguards are dismantled or deactivated, the industrial robot may not be operated.

**⚠ DANGER** Standing underneath the robot arm can cause death or injuries. For this reason, standing underneath the robot arm is prohibited!

**⚠ CAUTION** The motors reach temperatures during operation which can cause burns to the skin. Contact must be avoided. Appropriate safety precautions must be taken, e.g. protective gloves must be worn.

#### KCP/smartPAD

The user must ensure that the industrial robot is only operated with the KCP/smartPAD by authorized persons.

If more than one KCP/smartPAD is used in the overall system, it must be ensured that each device is unambiguously assigned to the corresponding industrial robot. They must not be interchanged.

**⚠ WARNING** The operator must ensure that decoupled KCPs/smartPADs are immediately removed from the system and stored out of sight and reach of personnel working on the industrial robot. This serves to prevent operational and non-operational EMERGENCY STOP devices from becoming interchanged. Failure to observe this precaution may result in death, severe injuries or considerable damage to property.

#### External keyboard, external mouse

An external keyboard and/or external mouse may only be used if the following conditions are met:

- Start-up or maintenance work is being carried out.
- The drives are switched off.
- There are no persons in the danger zone.

The KCP/smartPAD must not be used as long as an external keyboard and/or external mouse are connected to the control cabinet.

The external keyboard and/or external mouse must be removed from the control cabinet as soon as the start-up or maintenance work is completed or the KCP/smartPAD is connected.

<b>Modifications</b>	<p>After modifications to the industrial robot, checks must be carried out to ensure the required safety level. The valid national or regional work safety regulations must be observed for this check. The correct functioning of all safety functions must also be tested.</p> <p>New or modified programs must always be tested first in Manual Reduced Velocity mode (T1).</p> <p>After modifications to the industrial robot, existing programs must always be tested first in Manual Reduced Velocity mode (T1). This applies to all components of the industrial robot and includes modifications to the software and configuration settings.</p>
<b>Faults</b>	<p>The following tasks must be carried out in the case of faults in the industrial robot:</p> <ul style="list-style-type: none"> <li>■ Switch off the robot controller and secure it (e.g. with a padlock) to prevent unauthorized persons from switching it on again.</li> <li>■ Indicate the fault by means of a label with a corresponding warning (tag-out).</li> <li>■ Keep a record of the faults.</li> <li>■ Eliminate the fault and carry out a function test.</li> </ul>

### 5.5.2 Transportation

<b>Manipulator</b>	<p>The prescribed transport position of the manipulator must be observed. Transportation must be carried out in accordance with the operating instructions or assembly instructions of the robot.</p> <p>Avoid vibrations and impacts during transportation in order to prevent damage to the manipulator.</p>
<b>Robot controller</b>	<p>The prescribed transport position of the robot controller must be observed. Transportation must be carried out in accordance with the operating instructions or assembly instructions of the robot controller.</p> <p>Avoid vibrations and impacts during transportation in order to prevent damage to the robot controller.</p>
<b>External axis (optional)</b>	<p>The prescribed transport position of the external axis (e.g. KUKA linear unit, turn-tilt table, positioner) must be observed. Transportation must be carried out in accordance with the operating instructions or assembly instructions of the external axis.</p>

### 5.5.3 Start-up and recommissioning

Before starting up systems and devices for the first time, a check must be carried out to ensure that the systems and devices are complete and operational, that they can be operated safely and that any damage is detected.

The valid national or regional work safety regulations must be observed for this check. The correct functioning of all safety circuits must also be tested.



The passwords for logging onto the KUKA System Software as “Expert” and “Administrator” must be changed before start-up and must only be communicated to authorized personnel.



The robot controller is preconfigured for the specific industrial robot. If cables are interchanged, the manipulator and the external axes (optional) may receive incorrect data and can thus cause personal injury or material damage. If a system consists of more than one manipulator, always connect the connecting cables to the manipulators and their corresponding robot controllers.



If additional components (e.g. cables), which are not part of the scope of supply of KUKA Roboter GmbH, are integrated into the industrial robot, the user is responsible for ensuring that these components do not adversely affect or disable safety functions.

### NOTICE

If the internal cabinet temperature of the robot controller differs greatly from the ambient temperature, condensation can form, which may cause damage to the electrical components. Do not put the robot controller into operation until the internal temperature of the cabinet has adjusted to the ambient temperature.

## Function test

The following tests must be carried out before start-up and recommissioning: It must be ensured that:

- The industrial robot is correctly installed and fastened in accordance with the specifications in the documentation.
- There are no foreign bodies or loose parts on the industrial robot.
- All required safety equipment is correctly installed and operational.
- The power supply ratings of the industrial robot correspond to the local supply voltage and mains type.
- The ground conductor and the equipotential bonding cable are sufficiently rated and correctly connected.
- The connecting cables are correctly connected and the connectors are locked.

## Machine data

It must be ensured that the rating plate on the robot controller has the same machine data as those entered in the declaration of incorporation. The machine data on the rating plate of the manipulator and the external axes (optional) must be entered during start-up.



**WARNING** The industrial robot must not be moved if incorrect machine data are loaded. Death, severe injuries or considerable damage to property may otherwise result. The correct machine data must be loaded.

### 5.5.4 Manual mode

Manual mode is the mode for setup work. Setup work is all the tasks that have to be carried out on the industrial robot to enable automatic operation. Setup work includes:

- Jog mode
- Teaching
- Programming
- Program verification

The following must be taken into consideration in manual mode:

- If the drives are not required, they must be switched off to prevent the manipulator or the external axes (optional) from being moved unintentionally.

- New or modified programs must always be tested first in Manual Reduced Velocity mode (T1).
- The manipulator, tooling or external axes (optional) must never touch or project beyond the safety fence.
- Workpieces, tooling and other objects must not become jammed as a result of the industrial robot motion, nor must they lead to short-circuits or be liable to fall off.
- All setup work must be carried out, where possible, from outside the safeguarded area.

If the setup work has to be carried out inside the safeguarded area, the following must be taken into consideration:

**In Manual Reduced Velocity mode (T1):**

- If it can be avoided, there must be no other persons inside the safeguarded area.  
If it is necessary for there to be several persons inside the safeguarded area, the following must be observed:
  - Each person must have an enabling device.
  - All persons must have an unimpeded view of the industrial robot.
  - Eye-contact between all persons must be possible at all times.
- The operator must be so positioned that he can see into the danger area and get out of harm's way.

**In Manual High Velocity mode (T2):**

- This mode may only be used if the application requires a test at a velocity higher than Manual Reduced Velocity.
- Teaching and programming are not permissible in this operating mode.
- Before commencing the test, the operator must ensure that the enabling devices are operational.
- The operator must be positioned outside the danger zone.
- There must be no other persons inside the safeguarded area. It is the responsibility of the operator to ensure this.

### 5.5.5 Automatic mode

Automatic mode is only permissible in compliance with the following safety measures:

- All safety equipment and safeguards are present and operational.
- There are no persons in the system.
- The defined working procedures are adhered to.

If the manipulator or an external axis (optional) comes to a standstill for no apparent reason, the danger zone must not be entered until an EMERGENCY STOP has been triggered.

### 5.5.6 Maintenance and repair

After maintenance and repair work, checks must be carried out to ensure the required safety level. The valid national or regional work safety regulations must be observed for this check. The correct functioning of all safety functions must also be tested.

The purpose of maintenance and repair work is to ensure that the system is kept operational or, in the event of a fault, to return the system to an operational state. Repair work includes troubleshooting in addition to the actual repair itself.



The following safety measures must be carried out when working on the industrial robot:

- Carry out work outside the danger zone. If work inside the danger zone is necessary, the user must define additional safety measures to ensure the safe protection of personnel.
- Switch off the industrial robot and secure it (e.g. with a padlock) to prevent it from being switched on again. If it is necessary to carry out work with the robot controller switched on, the user must define additional safety measures to ensure the safe protection of personnel.
- If it is necessary to carry out work with the robot controller switched on, this may only be done in operating mode T1.
- Label the system with a sign indicating that work is in progress. This sign must remain in place, even during temporary interruptions to the work.
- The EMERGENCY STOP systems must remain active. If safety functions or safeguards are deactivated during maintenance or repair work, they must be reactivated immediately after the work is completed.

 **WARNING** Before work is commenced on live parts of the robot system, the main switch must be turned off and secured against being switched on again by unauthorized personnel. The incoming power cable must be deenergized. The robot controller and mains supply lead must then be checked to ensure that it is deenergized. If the KR C4 or VKR C4 robot controller is used: It is not sufficient, before commencing work on live parts, to execute an EMERGENCY STOP or a safety stop, or to switch off the drives, as this does not disconnect the robot system from the mains power supply in the case of the drives of the new generation. Parts remain energized. Death or severe injuries may result.

Faulty components must be replaced using new components with the same article numbers or equivalent components approved by KUKA Roboter GmbH for this purpose.

Cleaning and preventive maintenance work is to be carried out in accordance with the operating instructions.

### Robot controller

Even when the robot controller is switched off, parts connected to peripheral devices may still carry voltage. The external power sources must therefore be switched off if work is to be carried out on the robot controller.

The ESD regulations must be adhered to when working on components in the robot controller.

Voltages in excess of 50 V (up to 600 V) can be present in various components for several minutes after the robot controller has been switched off! To prevent life-threatening injuries, no work may be carried out on the industrial robot in this time.

Water and dust must be prevented from entering the robot controller.

### Counterbalancing system

Some robot variants are equipped with a hydropneumatic, spring or gas cylinder counterbalancing system.

The hydropneumatic and gas cylinder counterbalancing systems are pressure equipment and, as such, are subject to obligatory equipment monitoring and the provisions of the Pressure Equipment Directive.

The user must comply with the applicable national laws, regulations and standards pertaining to pressure equipment.

Inspection intervals in Germany in accordance with Industrial Safety Order, Sections 14 and 15. Inspection by the user before commissioning at the installation site.

The following safety measures must be carried out when working on the counterbalancing system:

- The manipulator assemblies supported by the counterbalancing systems must be secured.
- Work on the counterbalancing systems must only be carried out by qualified personnel.

#### Hazardous substances

The following safety measures must be carried out when handling hazardous substances:

- Avoid prolonged and repeated intensive contact with the skin.
- Avoid breathing in oil spray or vapors.
- Clean skin and apply skin cream.



To ensure safe use of our products, we recommend that our customers regularly request up-to-date safety data sheets from the manufacturers of hazardous substances.

#### 5.5.7 Decommissioning, storage and disposal

The industrial robot must be decommissioned, stored and disposed of in accordance with the applicable national laws, regulations and standards.

#### 5.6 Applied norms and regulations

Name	Definition	Edition
2006/42/EC	<b>Machinery Directive:</b> Directive 2006/42/EC of the European Parliament and of the Council of 17 May 2006 on machinery, and amending Directive 95/16/EC (recast)	2006
2004/108/EC	<b>EMC Directive:</b> Directive 2004/108/EC of the European Parliament and of the Council of 15 December 2004 on the approximation of the laws of the Member States relating to electromagnetic compatibility and repealing Directive 89/336/EEC	2004
97/23/EC	<b>Pressure Equipment Directive:</b> Directive 97/23/EC of the European Parliament and of the Council of 29 May 1997 on the approximation of the laws of the Member States concerning pressure equipment  (Only applicable for robots with hydropneumatic counterbalancing system.)	1997
EN ISO 13850	<b>Safety of machinery:</b> Emergency stop - Principles for design	2008
EN ISO 13849-1	<b>Safety of machinery:</b> Safety-related parts of control systems - Part 1: General principles of design	2008

<b>EN ISO 13849-2</b>	<b>Safety of machinery:</b> Safety-related parts of control systems - Part 2: Validation	2012
<b>EN ISO 12100</b>	<b>Safety of machinery:</b> General principles of design, risk assessment and risk reduction	2010
<b>EN ISO 10218-1</b>	<b>Industrial robots:</b> Safety <b>Note:</b> Content equivalent to <b>ANSI/RIA R.15.06-2012, Part 1</b>	2011
<b>EN 614-1</b>	<b>Safety of machinery:</b> Ergonomic design principles - Part 1: Terms and general principles	2009
<b>EN 61000-6-2</b>	<b>Electromagnetic compatibility (EMC):</b> Part 6-2: Generic standards; Immunity for industrial environments	2005
<b>EN 61000-6-4 + A1</b>	<b>Electromagnetic compatibility (EMC):</b> Part 6-4: Generic standards; Emission standard for industrial environments	2011
<b>EN 60204-1 + A1</b>	<b>Safety of machinery:</b> Electrical equipment of machines - Part 1: General requirements	2009



## 6 Planning

### 6.1 Information for planning

In the planning and design phase, care must be taken regarding the functions or applications to be executed by the kinematic system. The following conditions can lead to premature wear. They necessitate shorter maintenance intervals and/or earlier exchange of components. In addition, the permissible operating parameters specified in the technical data must be taken into account during planning.

- Continuous operation near temperature limits or in abrasive environments
- Continuous operation close to the performance limits, e.g. high rpm of an axis
- High duty cycle of individual axes
- Monotonous motion profiles, e.g. short, frequently recurring axis motions
- Static axis positions, e.g. continuous vertical position of a wrist axis

If one or more of these conditions are to apply during operation of the kinematic system, KUKA Roboter GmbH must be consulted.

### 6.2 Mounting base with centering

**Description** The mounting base with centering is used when the robot is fastened to the floor, i.e. directly on a concrete foundation.

The mounting base with centering consists of:

- Bedplates
- Resin-bonded anchors (chemical anchors)
- Fastening elements

This mounting variant requires a level and smooth surface on a concrete foundation with adequate load bearing capacity. The concrete foundation must be able to accommodate the forces occurring during operation. There must be no layers of insulation or screed between the bedplates and the concrete foundation.

The minimum dimensions must be observed.

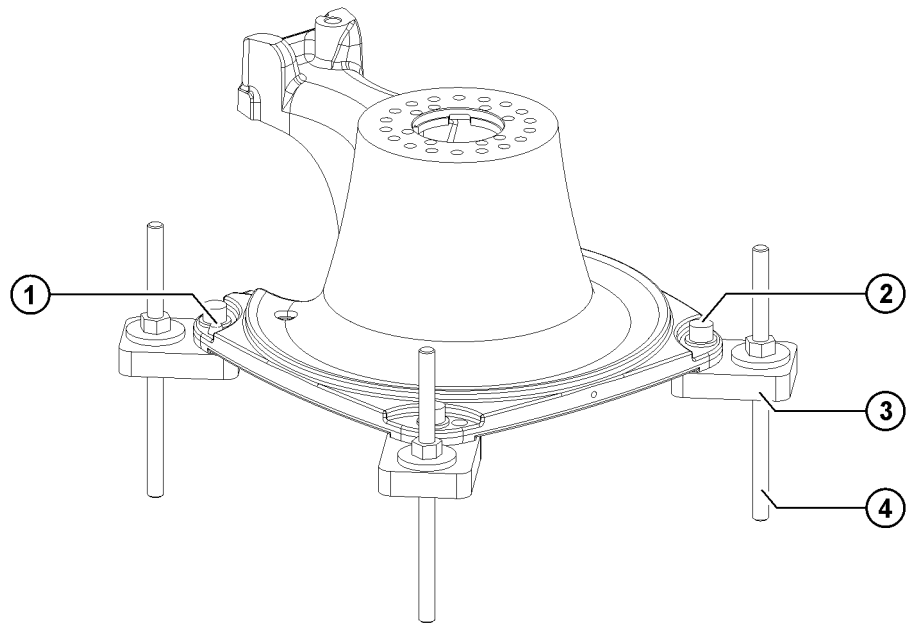

**Fig. 6-1: Mounting base with centering**

- 1 Locating pin for centering
- 2 Allen screw
- 3 Bedplate
- 4 Resin-bonded anchor

**Grade of concrete for foundations**

When producing foundations from concrete, observe the load-bearing capacity of the ground and the country-specific construction regulations. There must be no layers of insulation or screed between the bedplates and the concrete foundation. The quality of the concrete must meet the requirements of the following standard:

- C20/25 according to DIN EN 206-1:2001/DIN 1045-2:2008

**Dimensioned drawing**

The following illustration (>>> Fig. 6-2 ) provides all the necessary information on the mounting base, together with the required foundation data.

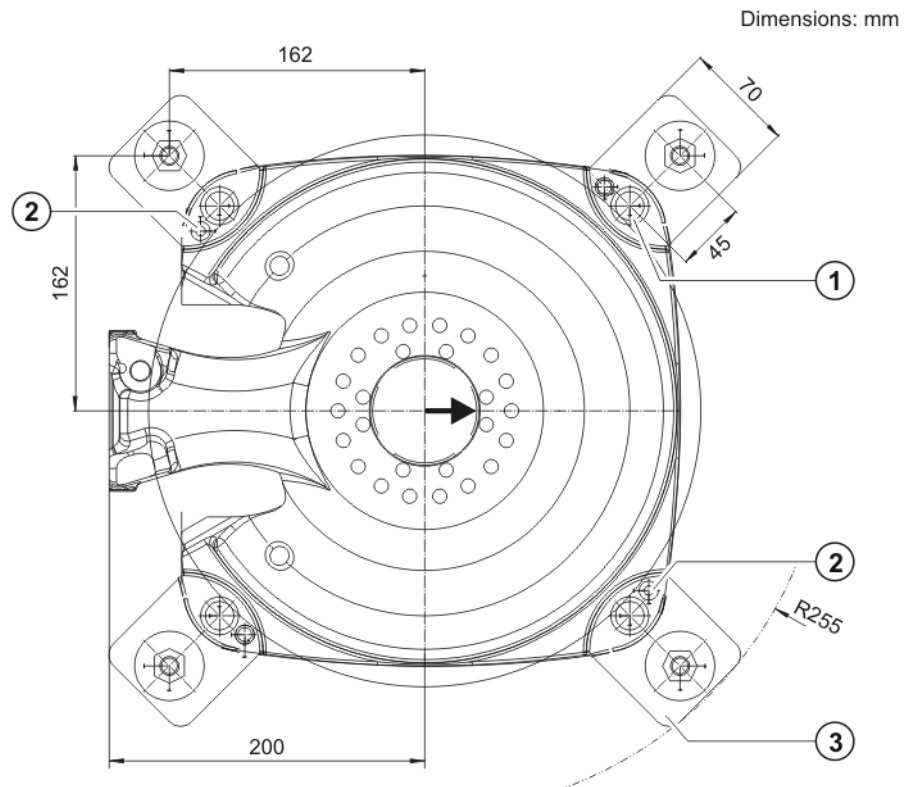

**Fig. 6-2: Mounting base with centering, dimensioned drawing**

- 1 Allen screws
- 2 Locating pin, long
- 3 Bedplate

To ensure that the anchor forces are safely transmitted to the foundation, observe the dimensions for concrete foundations specified in the following illustration (>>> Fig. 6-3 ).

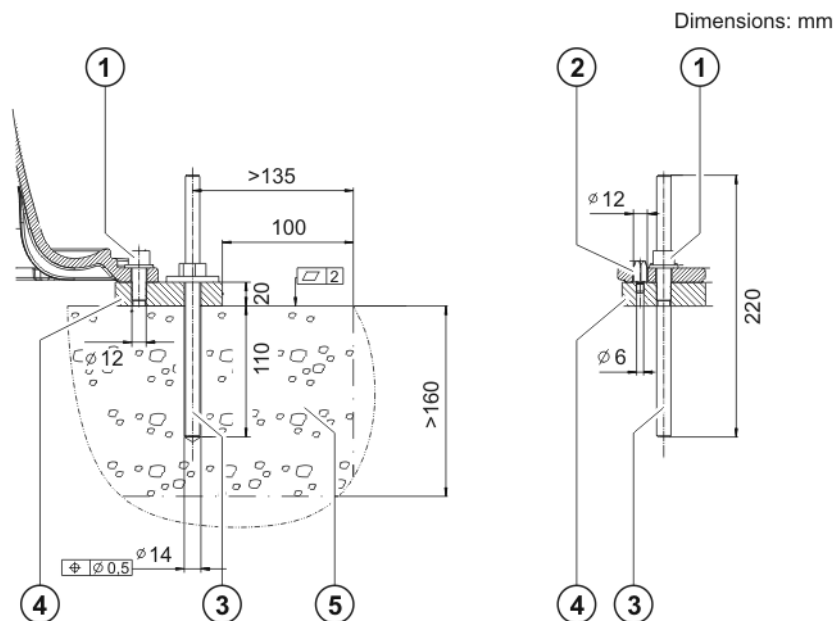

**Fig. 6-3: Cross-section of foundations**

- |   |                     |   |                     |
|---|---------------------|---|---------------------|
| 1 | Allen screw         | 4 | Bedplate            |
| 2 | Locating pin        | 5 | Concrete foundation |
| 3 | Resin-bonded anchor |   |                     |

### 6.3 Machine frame mounting with centering

#### Description

The machine frame mounting with centering is used for installing the robot on a steel structure provided by the customer or on a carriage of a KUKA linear unit. The mounting surface for the robot must be machined and of an appropriate quality. The robot is fastened to the machine frame mounting option using 4 Allen screws. Two locating pins are used for centering.

The machine frame mounting assembly consists of:

- Locating pins
- Fasteners

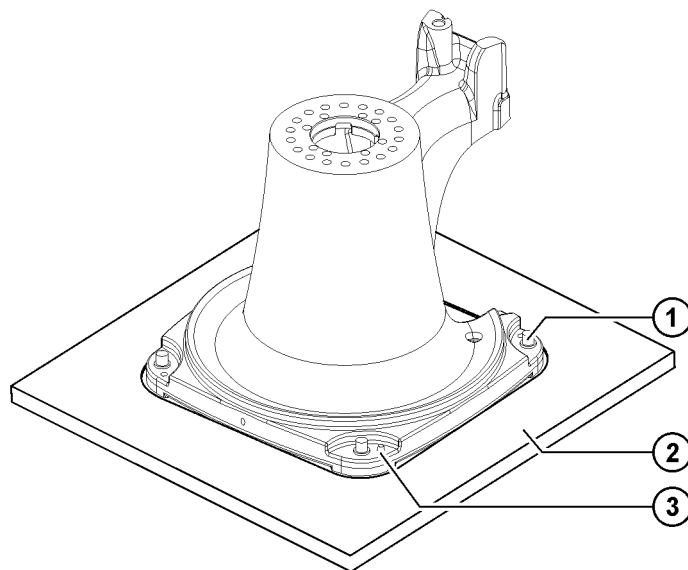

**Fig. 6-4: Machine frame mounting**

- |   |  |
|---|--|
| 1 | Allen screw with conical spring washer |
| 2 | Mounting surface                       |
| 3 | Locating pin                           |

#### Dimensioned drawing

The following illustrations provide all the necessary information on machine frame mounting, together with the required foundation data.



Dimensions: mm

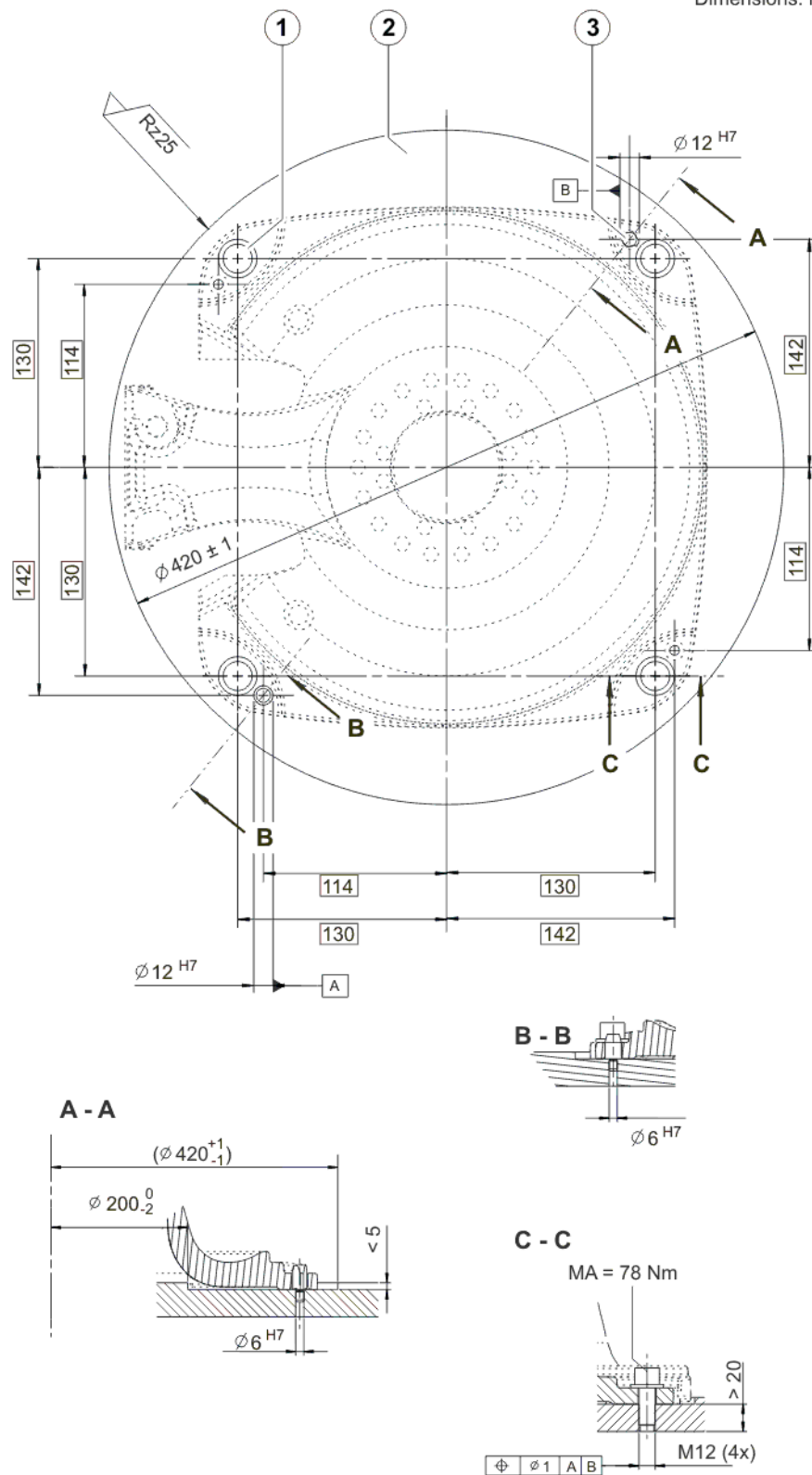

**Fig. 6-5: Machine frame mounting with centering**

- 1 Allen screw
- 2 Mounting surface, machined
- 3 Locating pin

## 6.4 Adapter plate

### Description

The adapter plate enables the robot to be fastened to

- mounting bases
- steel structures
- carriages of KUKA linear units

which are already equipped with the hole pattern for the KR 6.

The mounting surface for the adapter plate (>>> Fig. 6-6 ) must be machined and of an appropriate quality. The adapter plate is fastened to the mounting base with the KR 6 hole pattern with 3 hexagon bolts. 2 pins are used for centering. The robot is fastened to the adapter plate using 4 Allen screws. 2 locating pins are used for centering.

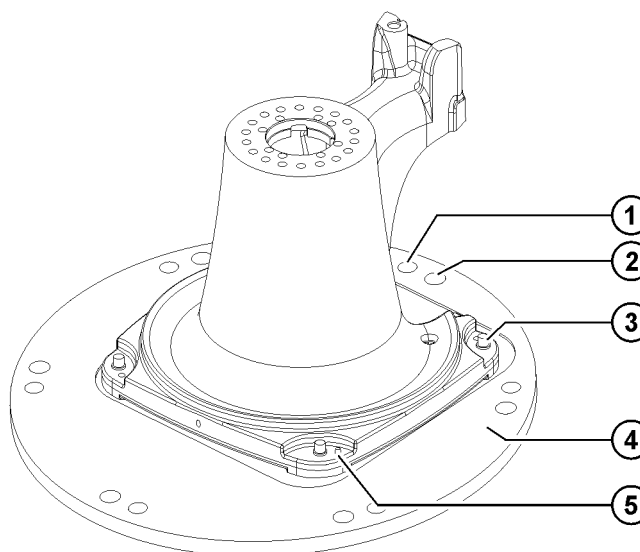

**Fig. 6-6: Adapter plate**

- 1 Pin for centering the adapter plate
- 2 Hexagon bolt with conical spring washer
- 3 Allen screw with conical spring washer
- 4 Adapter plate
- 5 Locating pin

## 6.5 Connecting cables and interfaces

### Connecting cables

The connecting cables comprise all the cables for transferring energy and signals between the robot and the robot controller. They are connected to the robot junction boxes with connectors. The set of connecting cables comprises:

- Motor cable, X20 - X30
- Control cable, X21 - X31
- 2nd control cable, X21.1 - X41 (only with SafeRobot)
- Ground conductor (optional)

Depending on the specification of the robot, various connecting cables are used. Cable lengths of 7 m, 15 m, 25 m, 35 m and 50 m are available. The maximum length of the connecting cables must not exceed 50 m. With SafeRobot, the maximum cable length of 35 m must not be exceeded. Thus if the robot is operated on a linear unit which has its own energy supply chain these cables must also be taken into account.

For connecting cables of length > 25 m an additional ground conductor is required to provide a low-resistance connection between the robot and the control cabinet in accordance with DIN EN 60204. The ground conductors are connected via ring cable lugs. The threaded bolt for connecting the ground conductor is located on the base frame of the robot.

The following points must be observed when planning and routing the connecting cables:

- The bending radius for fixed routing must not be less than 150 mm for motor cables and 60 mm for control cables.
- Protect cables against exposure to mechanical stress.
- Route the cables without mechanical stress – no tensile forces on the connectors
- Cables are only to be installed indoors.
- Observe permissible temperature range (fixed installation) of 263 K (-10 °C) to 343 K (+70 °C).
- Route the motor cables and the data cables separately in metal ducts; if necessary, additional measures must be taken to ensure electromagnetic compatibility (EMC).

### Interface for energy supply system

No energy supply system is implemented for the robot.

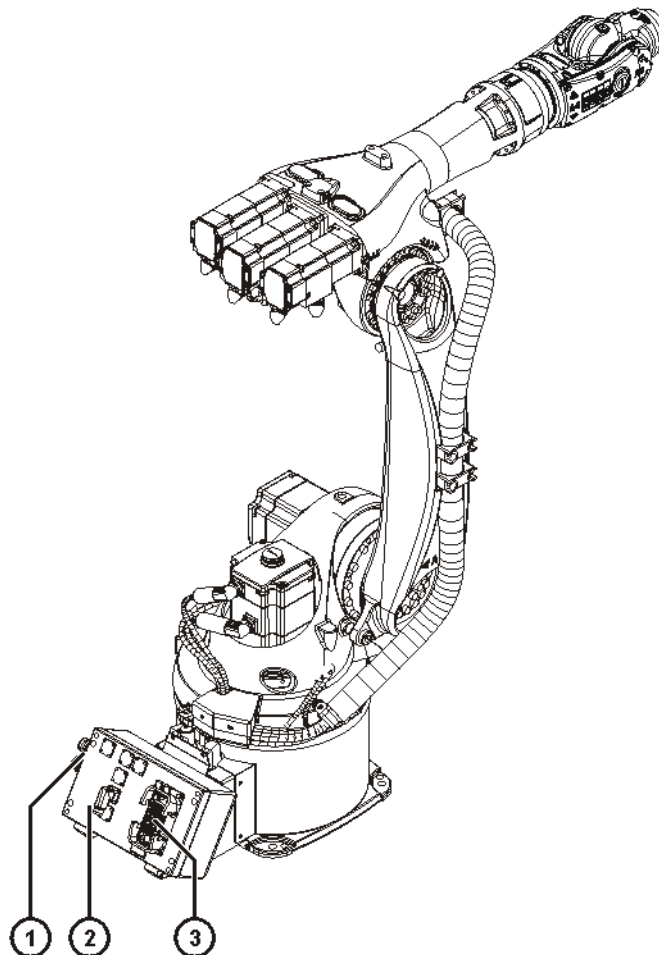

**Fig. 6-7: Connecting cables, example: KR C2**

- 1 Connection, motor cable X30
- 2 2nd control cable X41 (for SafeRobot only)
- 3 Connection, control cable X31



## 7 Transportation

### 7.1 Transporting the robot

**NOTICE** The connecting cables can be damaged during transportation. Fasten loose connecting cables to the robot before transportation.

Move the robot into its transport position each time it is transported. It must be ensured that the robot is stable while it is being transported. The robot must remain in its transport position until it has been fastened in position. Before the robot is lifted, it must be ensured that it is free from obstructions. Remove all transport safeguards, such as nails and screws, in advance. First remove any rust or glue on contact surfaces.

#### Transport position

The robot is in the transport position when the axes are in the following positions:

Axis	A 1	A 2	A 3	A 4	A 5	A 6
Angle	0°	-130°	+158°	0°	0°	0°

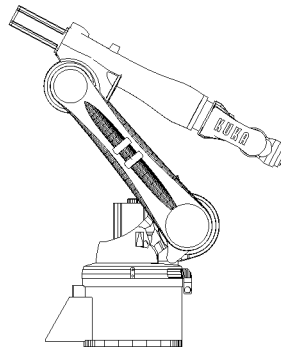

Fig. 7-1: Transport position

#### Transport dimensions

The transport dimensions for the robot can be noted from the following diagram. The position of the center of gravity and the weight vary according to the specific configuration. The specified dimensions refer to the robot without equipment.

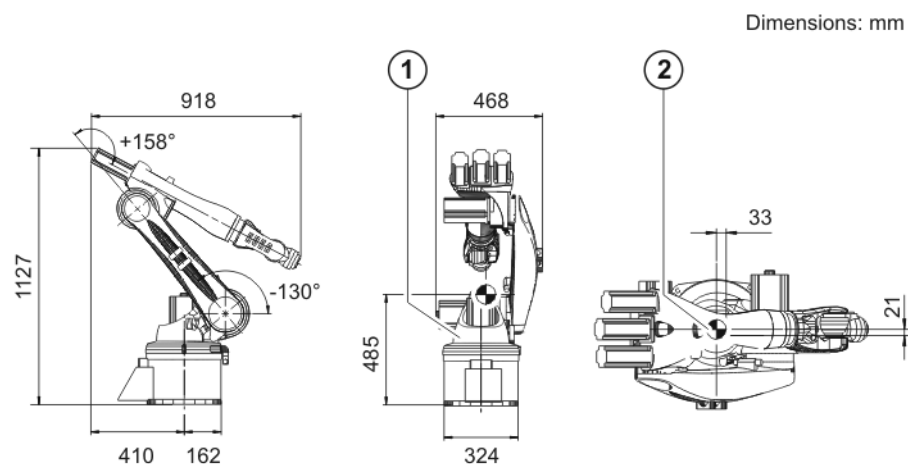

Fig. 7-2: Transport dimensions

1 Robot

2 Center of gravity

**Transportation**

The floor-mounted robot is transported using lifting tackle, and the ceiling-mounted robot by fork lift truck.

**WARNING** Use of unsuitable handling equipment may result in damage to the robot or injury to persons. Only use authorized handling equipment with a sufficient load-bearing capacity. Only transport the robot in the manner specified here.

**Transportation by fork lift truck**

The ceiling-mounted robot is transported using a fork lift truck. For transport by fork lift truck (>>> Fig. 7-3 ), the fork slots must be installed. The robot must be in the transport position.

**NOTICE** Avoid excessive loading of the fork slots through undue inward or outward movement of hydraulically adjustable forks of the fork lift truck. Failure to do so may result in material damage.

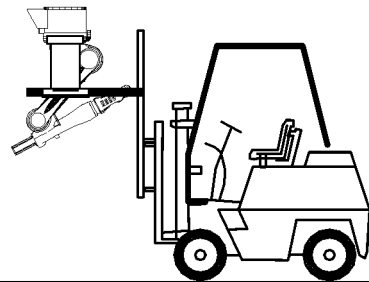

**Fig. 7-3: Transport by fork lift truck**

**Transportation using lifting tackle**

The floor-mounted robot is transported using lifting tackle. The robot must be in the transport position. One rope (>>> Fig. 7-4 ) of the lifting tackle is attached to an eyebolt that is screwed into the rotating column. A second rope is attached through an aperture in the rotating column. All ropes must be long enough and must be routed in such a way that the robot is not damaged. Installed tools and items of equipment can cause undesirable shifts in the center of gravity.

The eyebolt must be removed from the rotating column after transportation.

**WARNING** The robot may tip during transportation. Risk of personal injury and damage to property. If the robot is being transported using lifting tackle, special care must be exercised to prevent it from tipping. Additional safeguarding measures must be taken. It is forbidden to pick up the robot in any other way using a crane!

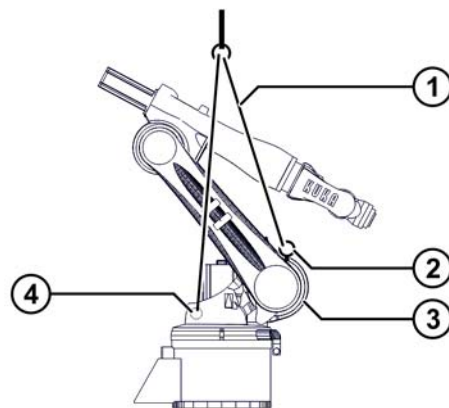

**Fig. 7-4: Lifting tackle**

- |   |         |   |                 |
|---|---------|---|-----------------|
| 1 | Rope    | 3 | Rotating column |
| 2 | Eyebolt | 4 | Hole            |





## 8 KUKA Service

### 8.1 Requesting support

<b>Introduction</b>	This documentation provides information on operation and operator control, and provides assistance with troubleshooting. For further assistance, please contact your local KUKA subsidiary.
<b>Information</b>	<p>The following information is required for processing a support request:</p> <ul style="list-style-type: none"> <li>■ Model and serial number of the manipulator</li> <li>■ Model and serial number of the controller</li> <li>■ Model and serial number of the linear unit (if present)</li> <li>■ Model and serial number of the energy supply system (if present)</li> <li>■ Version of the system software</li> <li>■ Optional software or modifications</li> <li>■ Diagnostic package <b>KrcDiag</b>:            Additionally for KUKA Sunrise: Existing projects including applications            For versions of KUKA System Software older than V8: Archive of the software (<b>KrcDiag</b> is not yet available here.)</li> <li>■ Application used</li> <li>■ External axes used</li> <li>■ Description of the problem, duration and frequency of the fault</li> </ul>

### 8.2 KUKA Customer Support

<b>Availability</b>	KUKA Customer Support is available in many countries. Please do not hesitate to contact us if you have any questions.
<b>Argentina</b>	<p>Ruben Costantini S.A. (Agency)          Luis Angel Huergo 13 20          Parque Industrial          2400 San Francisco (CBA)          Argentina          Tel. +54 3564 421033          Fax +54 3564 428877          ventas@costantini-sa.com</p>
<b>Australia</b>	<p>KUKA Robotics Australia Pty Ltd          45 Fennell Street          Port Melbourne VIC 3207          Australia          Tel. +61 3 9939 9656          GregSale@kuka-robotics.com.au          www.kuka-robotics.com.au</p>

<b>Belgium</b>	KUKA Automatisering + Robots N.V. Centrum Zuid 1031 3530 Houthalen Belgium Tel. +32 11 516160 Fax +32 11 526794 info@kuka.be www.kuka.be
<b>Brazil</b>	KUKA Roboter do Brasil Ltda. Travessa Claudio Armando, nº 171 Bloco 5 - Galpões 51/52 Bairro Assunção CEP 09861-7630 São Bernardo do Campo - SP Brazil Tel. +55 11 4942-8299 Fax +55 11 2201-7883 info@kuka-roboter.com.br www.kuka-roboter.com.br
<b>Chile</b>	Robotec S.A. (Agency) Santiago de Chile Chile Tel. +56 2 331-5951 Fax +56 2 331-5952 robotec@robotec.cl www.robotec.cl
<b>China</b>	KUKA Robotics China Co., Ltd. No. 889 Kungang Road Xiaokunshan Town Songjiang District 201614 Shanghai P. R. China Tel. +86 21 5707 2688 Fax +86 21 5707 2603 info@kuka-robotics.cn www.kuka-robotics.com
<b>Germany</b>	KUKA Roboter GmbH Zugspitzstr. 140 86165 Augsburg Germany Tel. +49 821 797-4000 Fax +49 821 797-1616 info@kuka-roboter.de www.kuka-roboter.de

**France** KUKA Automatismes + Robotique SAS  
Techvallée  
6, Avenue du Parc  
91140 Villebon S/Yvette  
France  
Tel. +33 1 6931660-0  
Fax +33 1 6931660-1  
commercial@kuka.fr  
www.kuka.fr

**India** KUKA Robotics India Pvt. Ltd.  
Office Number-7, German Centre,  
Level 12, Building No. - 9B  
DLF Cyber City Phase III  
122 002 Gurgaon  
Haryana  
India  
Tel. +91 124 4635774  
Fax +91 124 4635773  
info@kuka.in  
www.kuka.in

**Italy** KUKA Roboter Italia S.p.A.  
Via Pavia 9/a - int.6  
10098 Rivoli (TO)  
Italy  
Tel. +39 011 959-5013  
Fax +39 011 959-5141  
kuka@kuka.it  
www.kuka.it

**Japan** KUKA Robotics Japan K.K.  
YBP Technical Center  
134 Godo-cho, Hodogaya-ku  
Yokohama, Kanagawa  
240 0005  
Japan  
Tel. +81 45 744 7691  
Fax +81 45 744 7696  
info@kuka.co.jp

**Canada** KUKA Robotics Canada Ltd.  
6710 Maritz Drive - Unit 4  
Mississauga  
L5W 0A1  
Ontario  
Canada  
Tel. +1 905 670-8600  
Fax +1 905 670-8604  
info@kukarobotics.com  
www.kuka-robotics.com/canada

<b>Korea</b>	KUKA Robotics Korea Co. Ltd. RIT Center 306, Gyeonggi Technopark 1271-11 Sa 3-dong, Sangnok-gu Ansan City, Gyeonggi Do 426-901 Korea Tel. +82 31 501-1451 Fax +82 31 501-1461 info@kukakorea.com
<b>Malaysia</b>	KUKA Robot Automation (M) Sdn Bhd South East Asia Regional Office No. 7, Jalan TPP 6/6 Taman Perindustrian Puchong 47100 Puchong Selangor Malaysia Tel. +60 (03) 8063-1792 Fax +60 (03) 8060-7386 info@kuka.com.my
<b>Mexico</b>	KUKA de México S. de R.L. de C.V. Progreso #8 Col. Centro Industrial Puente de Vigas Tlalnepantla de Baz 54020 Estado de México Mexico Tel. +52 55 5203-8407 Fax +52 55 5203-8148 info@kuka.com.mx www.kuka-robotics.com/mexico
<b>Norway</b>	KUKA Sveiseanlegg + Roboter Sentrumsvegen 5 2867 Hov Norway Tel. +47 61 18 91 30 Fax +47 61 18 62 00 info@kuka.no
<b>Austria</b>	KUKA Roboter CEE GmbH Gruberstraße 2-4 4020 Linz Austria Tel. +43 7 32 78 47 52 Fax +43 7 32 79 38 80 office@kuka-roboter.at www.kuka.at

**Poland** KUKA Roboter Austria GmbH  
Spółka z ograniczoną odpowiedzialnością  
Oddział w Polsce  
Ul. Porcelanowa 10  
40-246 Katowice  
Poland  
Tel. +48 327 30 32 13 or -14  
Fax +48 327 30 32 26  
ServicePL@kuka-roboter.de

**Portugal** KUKA Sistemas de Automatización S.A.  
Rua do Alto da Guerra n° 50  
Armazém 04  
2910 011 Setúbal  
Portugal  
Tel. +351 265 729780  
Fax +351 265 729782  
kuka@mail.telepac.pt

**Russia** KUKA Robotics RUS  
Werbnaja ul. 8A  
107143 Moskau  
Russia  
Tel. +7 495 781-31-20  
Fax +7 495 781-31-19  
info@kuka-robotics.ru  
www.kuka-robotics.ru

**Sweden** KUKA Svetsanläggningar + Robotar AB  
A. Odhners gata 15  
421 30 Västra Frölunda  
Sweden  
Tel. +46 31 7266-200  
Fax +46 31 7266-201  
info@kuka.se

**Switzerland** KUKA Roboter Schweiz AG  
Industriestr. 9  
5432 Neuenhof  
Switzerland  
Tel. +41 44 74490-90  
Fax +41 44 74490-91  
info@kuka-roboter.ch  
www.kuka-roboter.ch

<b>Spain</b>	KUKA Robots IBÉRICA, S.A. Pol. Industrial Torrent de la Pastera Carrer del Bages s/n 08800 Vilanova i la Geltrú (Barcelona) Spain Tel. +34 93 8142-353 Fax +34 93 8142-950 Comercial@kuka-e.com www.kuka-e.com
<b>South Africa</b>	Jendamark Automation LTD (Agency) 76a York Road North End 6000 Port Elizabeth South Africa Tel. +27 41 391 4700 Fax +27 41 373 3869 www.jendamark.co.za
<b>Taiwan</b>	KUKA Robot Automation Taiwan Co., Ltd. No. 249 Pujong Road Jungli City, Taoyuan County 320 Taiwan, R. O. C. Tel. +886 3 4331988 Fax +886 3 4331948 info@kuka.com.tw www.kuka.com.tw
<b>Thailand</b>	KUKA Robot Automation (M)SdnBhd Thailand Office c/o Maccall System Co. Ltd. 49/9-10 Soi Kingkaew 30 Kingkaew Road Tt. Rachatheva, A. Bangpli Samutprakarn 10540 Thailand Tel. +66 2 7502737 Fax +66 2 6612355 atika@ji-net.com www.kuka-roboter.de
<b>Czech Republic</b>	KUKA Roboter Austria GmbH Organisation Tschechien und Slowakei Sezemická 2757/2 193 00 Praha Horní Počernice Czech Republic Tel. +420 22 62 12 27 2 Fax +420 22 62 12 27 0 support@kuka.cz

**Hungary** KUKA Robotics Hungaria Kft.  
Fő út 140  
2335 Taksony  
Hungary  
Tel. +36 24 501609  
Fax +36 24 477031  
info@kuka-robotics.hu

**USA** KUKA Robotics Corporation  
51870 Shelby Parkway  
Shelby Township  
48315-1787  
Michigan  
USA  
Tel. +1 866 873-5852  
Fax +1 866 329-5852  
info@kukarobotics.com  
www.kukarobotics.com

**UK** KUKA Automation + Robotics  
Hereward Rise  
Halesowen  
B62 8AN  
UK  
Tel. +44 121 585-0800  
Fax +44 121 585-0900  
sales@kuka.co.uk





## Index

### Numbers

2004/108/EC 42  
 2006/42/EC 42  
 89/336/EEC 42  
 95/16/EC 42  
 97/23/EC 42

### A

Accessories 9, 31  
 Adapter plate 50  
 Ambient temperature, operation 13  
 Ambient temperature, operation, Safe RDC 13  
 Ambient temperature, start-up 13  
 Ambient temperature, storage 13  
 Ambient temperature, transportation 13  
 ANSI/RIA R.15.06-2012 43  
 Applied norms and regulations 42  
 Arm 9, 10  
 Automatic mode 40  
 Axes, number 13  
 Axis data 14  
 Axis range 33  
 Axis range limitation 35  
 Axis range monitoring 35

### B

Base frame 10, 11  
 Basic data 13  
 Brake defect 37  
 Brake release device 36  
 Braking distance 33

### C

Cable set 9  
 CE mark 32  
 Center of gravity 53  
 Cleaning work 41  
 Connecting cables 13, 31, 50  
 Connecting cables, cable lengths 14  
 Counterbalancing system 41

### D

Danger zone 33  
 Declaration of conformity 32  
 Declaration of incorporation 31, 32  
 Decommissioning 42  
 Description of the robot system 9  
 Dimensions, transport 53  
 Disposal 42  
 Documentation, industrial robot 5

### E

EC declaration of conformity 32  
 Electrical installations 10  
 Electromagnetic compatibility (EMC) 43  
 EMC Directive 32, 42  
 EN 60204-1 + A1 43  
 EN 61000-6-2 43

EN 61000-6-4 + A1 43  
 EN 614-1 43  
 EN ISO 10218-1 43  
 EN ISO 12100 43  
 EN ISO 13849-1 42  
 EN ISO 13849-2 43  
 EN ISO 13850 42  
 External axes 31, 33

### F

Faults 38  
 Function test 39

### G

General safety measures 37

### H

Handling equipment 54  
 Hazardous substances 42  
 Humidity rating 13

### I

In-line wrist 9, 10  
 Industrial robot 31  
 Intended use 32  
 Interfaces 50  
 Introduction 5  
 ISO 9283, repeatability 13

### K

KCP 9, 33, 37  
 Keyboard, external 37  
 KUKA Customer Support 57  
 KUKA smartPAD 33

### L

Labeling 36  
 Liability 31  
 Lifting tackle 54  
 Linear unit 31  
 Link arm 10  
 Loads acting on the mounting base 17  
 Low Voltage Directive 32

### M

Machine data 39  
 Machine frame mounting with centering 48  
 Machinery Directive 32, 42  
 Maintenance 40  
 Manipulator 31, 33  
 Manual mode 39  
 Mechanical axis range limitation 35  
 Mechanical end stops 35  
 Mounting base with centering 45  
 Mounting flange 10, 16  
 Mounting position 13  
 Mouse, external 37

**O**

Operator 33, 34  
Options 9, 31  
Overload 37

**P**

Payload diagram 16  
Payloads 15  
Personnel 33  
Planning 45  
Plant integrator 33  
Plates and labels 18  
Positioner 31  
Pressure Equipment Directive 41, 42  
Preventive maintenance work 41  
Principal components 9  
Principal loads, dynamic 13  
Product description 9  
Protection rating, in-line wrist 13  
Protection rating, robot 13  
Protective equipment, overview 35  
Purpose 7

**R**

Reaction distance 33  
Recommissioning 38  
Reference point 13  
Relative air humidity 13  
Release device 36  
Repair 40  
Repeatability 13  
Robot 9  
Robot controller 9, 31  
Robot system 9  
Rotating column 10

**S**

Safety 31  
Safety instructions 5  
Safety of machinery 42, 43  
Safety zone 33, 34  
Safety, general 31  
Service life 33  
Service, KUKA Roboter 57  
smartPAD 33, 37  
Software 9, 31  
Sound level 13  
Start-up 38  
STOP 0 33  
STOP 1 33  
STOP 2 33  
Stop category 0 33  
Stop category 1 33  
Stop category 2 33  
Stopping distance 33  
Stopping distances, ceiling-mounted robots 25  
Stopping distances, floor-mounted robots 19  
Stopping times, ceiling-mounted robots 25  
Stopping times, floor-mounted robots 19  
Storage 42  
Supplementary load 17

Support request 57  
Surface finish, paintwork 13  
System integrator 32, 33, 34

**T**

T1 33  
T2 33  
Teach pendant 9, 31  
Technical data 13  
Terms used, safety 33  
Training 7  
Transport position 53  
Transportation 38, 53  
Turn-tilt table 31

**U**

Use, contrary to intended use 31  
Use, improper 31  
User 33, 34  
Users 7

**V**

Volume of working envelope 13

**W**

Warnings 5  
Weight 13  
Working envelope 14  
Working range limitation 35  
Workspace 33, 34

